



CABG0318911

CATÁLOGO
2011-2012



FEDERAL
MOGUL

CARTER®

Bomba de Combustible

¿Qué es y para qué sirve el VIN?



El VIN o número de identificación del motor es una serie de dígitos que sirve –entre otras cosas– para identificar algunos componentes de la unidad.

Esta serie de dígitos se encuentra regularmente en el tablero del vehículo acompañado de un código de barras.

Para identificar la bomba de combustible que requiere un auto, debemos ubicar el octavo dígito del VIN (que nos indica el tipo de motor del vehículo) y el decimo dígito del VIN (que nos da el año del modelo).



EJEMPLO:



En este catálogo CARTER encontrarás una columna con el dígito 8 del VIN que te especifica el tipo del motor del vehículo, lo que t ayudará a asegurar tu aplicación cerrada para la bomba de gasolina correspondiente

EJEMPLO

MODELO	CIL.	LTS. (PC)	AÑOS	VIN.	TIPO BOMBA	No. PARTE	OBSERVACIONES	PAG.	FOTO	NOTA
Chrysler / Dodge / Hyundai / Plymouth										
NEON	L4	2.0 (122)	2001-05	C, F	MÓDULO	P75027M				T
NEON (SOHC y DOHC)	L4	2.0 (122)	2000	C	MÓDULO	P74824M	CC 4 PTS. = C / R			T
NEON (Tanque Plástico)	L4	2.0 (122)	1996-99	C	MÓDULO	P74732M	CC 4 PTS. = C / R			T
NEON (Tanque Metálico)	L4	2.0 (122)	1995-97	C	MÓDULO	P74676M	CC 4 PTS. = C / R			T
NEON SRT-4	L4	2.4 (148)	2003-06	S	MÓDULO	P76227B				

Nuevos Números de Parte

Te presentamos las nuevas aplicaciones Carter bomba de combustible. Estamos seguros que serán un éxito en tu negocio.

MODELO	CIL.	LTS. (PC)	AÑOS	VIN.	TIPO BOMBA	No. PARTE	OBSERVACIONES
VENTURE	V6	3.4 (205)	1997-01	E	KIT	P54252	CORTA Y LARGA PARA MÓDULO DE FABRICACIÓN NACIONAL
MONTANA	V6	3.5 (214)	2005-08	L	KIT	P54258	
MONTANA	V6	3.9 (240)	2006-08	1	KIT	P54258	
UPLANDER	V6	3.5 (214)	2005-08	L	KIT	P54258	
UPLANDER	V6	3.9 (240)	2006-08	1	KIT	P54258	
C-3500	V8	6.5 (395)	1999-03	F	KIT	P54243	CHASIS CABINA TANQUE DELANTERO
C-3500	V8	5.7 (350)	1998-2000	R	KIT	P90251	CHASIS CABINA MPFI PARA MÓDULO DE FABRICACIÓN NACIONAL
SUBURBAN	V8	5.7 (350)	1998-2000	R	KIT	P90251	MPFI PARA MÓDULO DE FABRICACIÓN NACIONAL
SILVERADO 1500	V8	4.3 (262)	1999-03	W	KIT	P90251	
SILVERADO 2500	V8	5.3 (325)	1999-02	T	KIT	P90251	
ASTRA	L4	1.8 (110)	1999-08	Z18XE	KIT	P54245	
ASTRA	L4	2.2 (134)	2002-03	Z22SE	KIT	P54245	
LUV	L4	2.2 (134)	1999-05	22LE	KIT	P54254	
C-3500	V8	5.7 (350)	1998-2000	R	KIT	P54140V	CHASIS CABINA TQUE. TRASERO PARA MÓDULO DE FABRICACIÓN NACIONAL
CHEVY MONZA	L4	1.4 (85)	1995-97	C14SE	KIT	P54127	FABRICACIÓN NACIONAL T.B.I
CHEVY MONZA	L4	1.6 (96)	1995-97	C16SE	KIT	P54127	FABRICACIÓN NACIONAL T.B.I
CHEVY MONZA	L4	1.4 (85)	1998-00	C14SE	KIT	P54128	FABRICACIÓN NACIONAL T.B.I
CHEVY MONZA	L4	1.6 (96)	1998-00	C16SE	KIT	P54128	FABRICACIÓN NACIONAL T.B.I

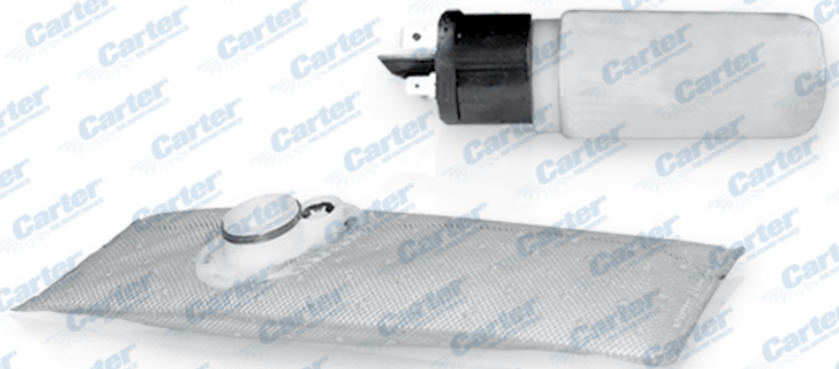

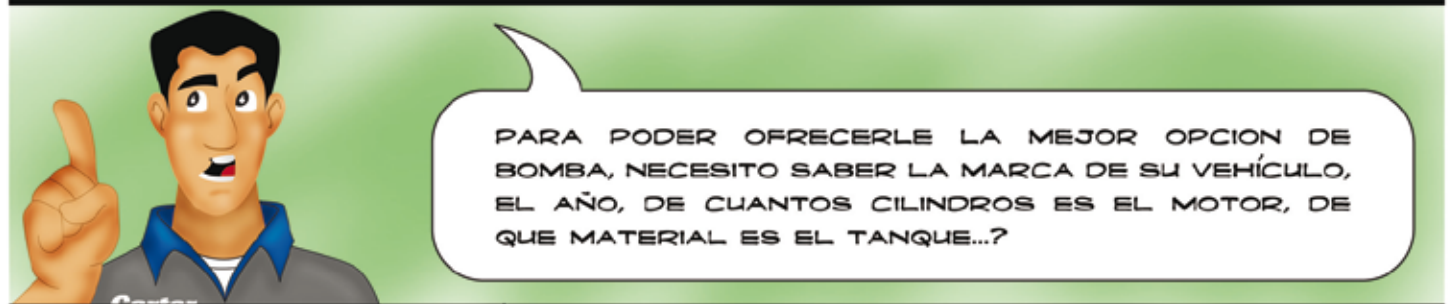

MIRE MI AMIGO, EL COMPRAR UNA BOMBA DE COMBUSTIBLE ES ALGO MUY SERIO, POR LO QUE ES IMPORTANTE PROPORCIONAR **TODA** LA INFORMACIÓN NECESARIA, DE OTRA FORMA LA VIDA ÚTIL DE LA BOMBA DISMINUYE AL NO SER LA CORRECTA PARA SU VEHÍCULO

"ESTE TIPO NO ES
REFACCIONARIO"

BUENO CONSIGO MAS DATOS
Y REGRESO MAS TARDE...

UNA HORA MAS TARDE...

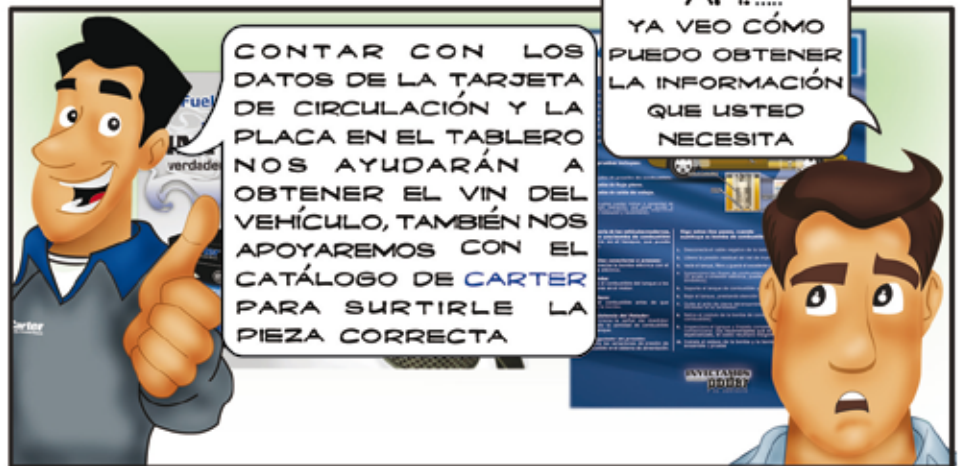

AH! YA ENTIENDO, AL SER **CARTER** UN PRODUCTO DE CALIDAD TIENE ESPECIFICACIONES PARA CADA TIPO DE CARRO, DE AHI LA IMPORTANCIA DE CONTAR CON TODA ESA INFORMACIÓN

¡DEFINITIVAMENTE **Carter** FUEL DELIVERY PRODUCTS
LE INYECTA VERDADERO PODER A MI VEHÍCULO!

Carter
FUEL DELIVERY PRODUCTS



ÍNDICE GENERAL

Motores a Gasolina

Página

APLICACIONES NACIONALES

Aplicaciones para vehículos nacionales	09
Aplicaciones para camionetas nacionales	19

APLICACIONES IMPORTADOS

Aplicaciones para vehículos importados	40
Aplicaciones para camionetas importados	55

FOTOGRAFÍAS

Fotografías por número de parte Nacionales e Importados	74
--	----

Motores a Diesel

Página

APLICACIONES PARA MOTORES A DIESEL

Bombas Eléctricas	67
Bombas Mecánicas	69
Fotografías por número de parte / Diesel	74

Bombas Mecánicas	67
Boletines Técnicos	151

ÍNDICE POR ARMADORAS

Vehículos Nacionales

Pág.

Camionetas Nacionales

Pág.

Chevrolet / Buick / Oldsmobile	09	Chevrolet / Pontiac / Cadillac	19
Chrysler / Dodge / Hyundai / Plymouth	10	Chrysler / Dodge	25
Ford / Lincoln / Mercury	13	Ford / Lincoln	31
Honda	14	Honda	36
Mitsubishi	15	Jeep	37
Nissan / Infiniti	15	Mitsubishi	37
Pontiac	16	Nissan	38
Toyota	16	Toyota	38
Volkswagen	17	Bombas eléctricas universales en línea	38
Bombas eléctricas universales en línea	18		

Vehículos Importados

Pág.

Pág.

Acura	40	Lexus	48
Audi	40	Lincoln	48
Bmw	40	Mazda	48
Buick	40	Mercury	49
Cadillac	41	Mitsubishi	49
Chevrolet	42	Nissan	49
Chrysler	44	Oldsmobile	50
Daihatsu	44	Peugeot	50
Delorean	44	Plymouth	50
Dodge	44	Pontiac	51
Ford	45	Sterling	51
Geo	46	Subaru	51
Honda	46	Suzuki	51
Hyundai	47	Toyota	51
Infiniti	47	Volkswagen	53
Isuzu	47	Volvo	53
Jeep	48	Bombas eléctricas universales en línea	53

ÍNDICE POR ARMADORAS

Camionetas Importados

Pág.

Motores a Diesel

Pág.

Cadillac	55	Bombas Eléctricas	67
Chevrolet	55	Dodge	67
Chrysler	58	Ford	67
Ford	60	General Motors	67
Geo	60	Bombas Mecánicas	68
GMC	61	Cummins	68
Honda	62	Dodge	68
Isuzu	62	Ford	68
Jeep	62	John Deere	68
Lexus	63		
Lincoln	63		
Mazda	63		
Mercury	64		
Mitsubishi	64		
Nissan	64		
Oldsmobile	64		
Plymouth	64		
Pontiac	65		
Sterling	65		
Subaru	65		
Suzuki	65		
Toyota	65		
Volkswagen	66		
Bombas eléctricas universales en línea	66		

Bombas Mecánicas

Pág.

AMC	69
Chevrolet / Buick / Oldsmobile	69
Chrysler	70
Dodge	70
Ford	70
Honda	72
Hyundai	72
International	72
Isuzu	72
Jeep	72
Mazda	72
Nissan	72
Suzuki	72
Toyota	73
Vam	73

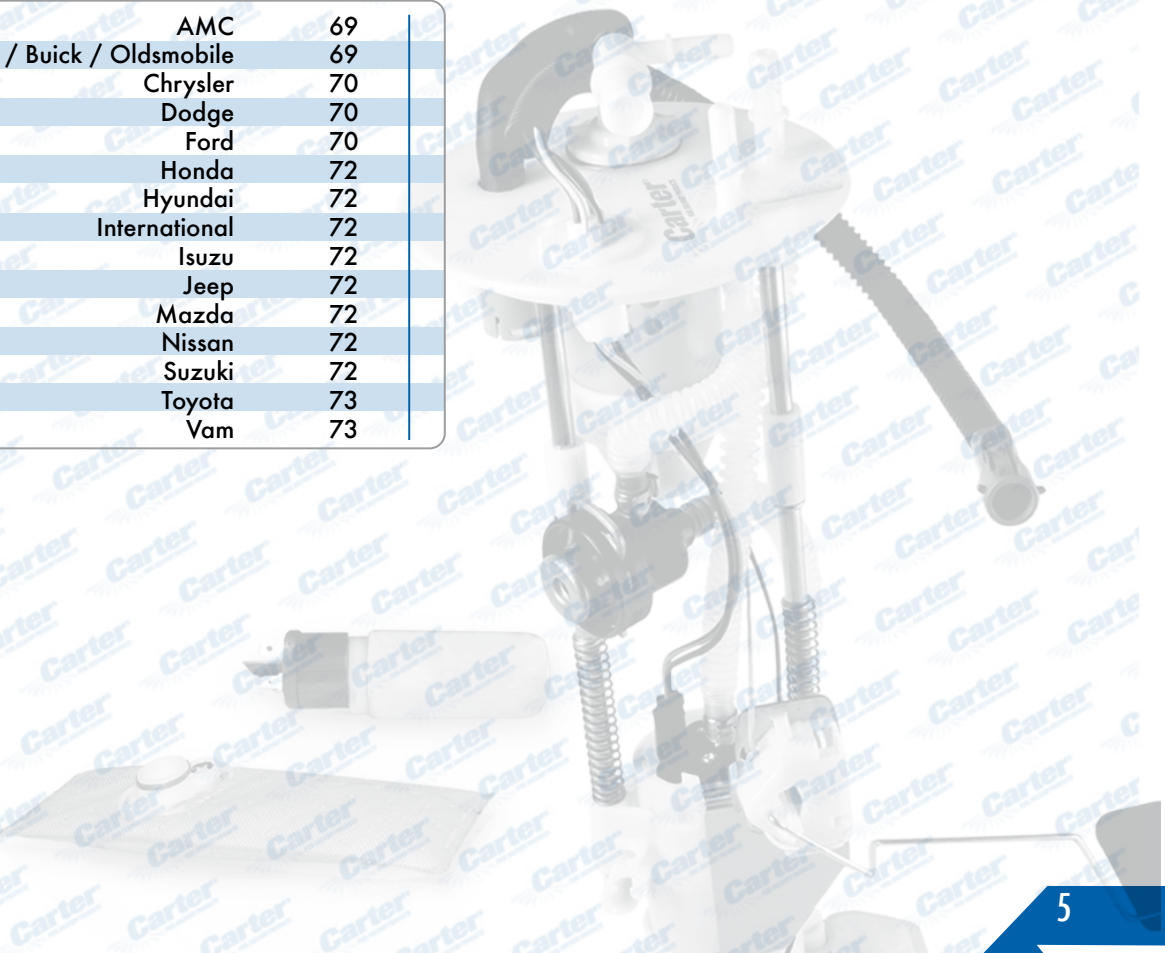

GLOSARIO

=	CONECTORES PLANOS
()	OTRAS REFERENCIAS
oo	CONECTORES REDONDOS
A / F	ALTURA DEL FOLTADOR
B / M	BASE MOVIBLE
C / R	CON REGULADOR INTEGRADO
C / SP	CON SENSOR DE PRESION
CBT	CODIGO DE LA BOMBA EN TANQUE
CC	CONECTOR
CHC	CHASIS CABINA
D / C	DISEÑO CARTER
D / E.O.	DISEÑO EQUIPO ORIGINAL
EL	EN LÍNEA
EN	ENSAMBLE
K	KIT
M	MÓDULO
MB	MEDIO BOTE
PTS	PUNTAS
S	SOPORTE
S / F	SIN FLOTADOR
S / R	SIN REGULADOR
SDB	SISTEMA DE DOBLE BOMBA
SL	SERVICIO LIGERO
SM	SERVICIO MEDIANO
RK	REPUESTO DEL KIT
TAG	ETIQUETA
TAMC	TANQUE A MEDIA CABINA
TBO	TURBO
TQE	TANQUE (CAPACIDAD ALMACENADA)
WB	WEEL BASE (DISTANCIA ENTRE EJES)
PI	PRÓXIMA INTEGRACIÓN
N	NUEVO NÚMERO DE PARTE



ABREVIATURAS

2WD	Tracción en dos ruedas	GVW	Peso bruto del vehículo	W/	Con
4WD	Tracción en las cuatro ruedas	H/D	Servicio pesado	WB	Distancia entre ejes
2WS	Dirección en dos ruedas	HI-PERF.	Alto rendimiento	W/O	Sin
4WS	Dirección en las cuatro ruedas	INCL.	Incluye	=	Conectores planos
ABS	Sistema de freno antibloqueo	L	Litro	oo	Conectores redondos
A/C	Aire acondicionado	LB	Plataforma larga	A/F	Altura del flotador
ALUM.	Aluminio	lb.	Libra	B/M	Base movable
A.R.	Relación de ejes	L.H.	Lado izquierdo	C/R	Con regulador integrado
ASSY.	Ensamble	LHD	Conducción por la izquierda	C/SP	Con sensor de presión
A/T	Transmisión automática	LTD.	Limitado	CBT	Código de la bomba en el tanque
AWD	Tracción en todas las ruedas	MAN.	Manual	CC	Conector
CALIF.	California	MH	Casa rodante	CHC	Chasis cabina
CARB.	Carburador	MM	Milímetro	EL	En línea
CAT. CONV.	Convertidor catalítico	M/T	Transmisión manual	MB	Medio bote
CYL.	Cilindro	MTD.	Montado	PTS	Puntas
DBL.	Doble	MTG.	Montaje	S/F	Sin flotador
DIA.	Diámetro	O/S	Sobremedida	S/R	Sin regulador
DOHC	Árbol de levas doble	OE	Equipo Original	SDB	Sistema de doble bomba
DR.	Puerta	OPT.	Opcional	SL	Servicio ligero
DRW	Ruedas traseras dobles	PC.	Pieza	SM	Servicio mediano
ELECT.	Eléctrico	PERF.	Rendimiento	RK	Repuesto del kit
ENG.	Motor	PKG.	Paquete	TAG	Etiqueta
EURO.	Europeo	R.G.	Corona	TAMC	Tanque a media cabina
EXC.	Excepto	REG.	Normal	TBO	Turbo
EXH.	Escape	R.H.	Lado derecho		
EXT.	Ampliada	RWD	Tracción en las ruedas traseras		
FC	Cabina delantera	SOHC	árbol de levas sencillo		
FI	Inyección de combustible	STD.	Estándar		
FWD	Tracción en las ruedas delanteras	WAGON	Familiar		

Gasolina

MODELO	CIL.	LTS. (PC)	AÑOS	VIN.	TIPO BOMBA	No. PARTE	OBSERVACIONES	PAG.	NOTA
--------	------	-----------	------	------	------------	-----------	---------------	------	------

Audi

N	A3 TURBO	L4	1.8 (110)	2000-05		MÓDULO	P90030M		131	
N	A3 TURBO	L4	1.8 (110)	2000-05		KIT	P90030		131	T
N	A3 TURBO	L4	2.0 (121)	2000-05		MÓDULO	P90030M		131	
N	A3 TURBO	L4	2.0 (121)	2000-05		KIT	P90030		131	T
N	A4 TURBO	L4	2.0 (121)	1999-05		MÓDULO	P90030M		131	
N	A4 TURBO	L4	2.0 (121)	1999-05		KIT	P90030		131	T

Chevrolet / Buick / Oldsmobile

	CAMARO	V8	5.7 (350)	1993-95	P	KIT	P74131		87	
	CAMARO	V8	5.7 (350)	1996-97	P	MÓDULO	P74782M		104	T
	CAVALIER	L4	2.2 (134)	1995	4	MÓDULO	P74688M		97	T
	CAVALIER	L4	2.2 (134)	1999	4	MÓDULO	P74781M		103	T
	CAVALIER	L4	2.2 (134)	1992-94	4	MÓDULO	P74826M		107	T
	CAVALIER	L4	2.2 (134)	2000-04	4	MÓDULO	P74831M		107	T
	CAVALIER	L4	2.2 (135)	1990-91	G	KIT	P74051	Número Anterior P75047	82	
	CAVALIER	L4	2.2 (135)	1996-98	4	ENSAMBLE	P74712S		99	T
	CAVALIER	L4	2.3 (138)	1995	D	MÓDULO	P74688M		97	T
	CAVALIER	L4	2.4 (156)	1999	T	MÓDULO	P74781M		103	T
	CAVALIER	L4	2.4 (135)	1996-98	T	ENSAMBLE	P74712S		99	T
	CAVALIER	L4	2.4 (156)	2000-02	T	MÓDULO	P74831M		107	T
	CAVALIER	V6	2.8 (173)	1988-89	W	KIT	P74037		82	
N	CAVALIER	V6	2.8 (173)	1988-89	W	KIT	P54000		72	
	CAVALIER	V6	2.8 (173)	1988-89	W	KIT	P74006		80	
N	CAVALIER	V6	2.8 (173)	1988-89	W	KIT	P54000		72	
	CAVALIER	V6	3.1 (189)	1992-94	T	MÓDULO	P74826M		107	T
	CAVALIER	V6	3.1 (183)	1992-94	T	KIT	P74129		87	
	CAVALIER Z24	V6	3.1 (183)	1990-91		KIT	P74037		82	
N	CAVALIER Z24	V6	3.1 (183)	1990-91		KIT	P54000		72	
	CELEBRITY	V6	2.8 (173)	1984-86	W	KIT	P60488		75	
N	CELEBRITY	V6	2.8 (173)	1988-89	W	KIT	P54000		72	
	CELEBRITY	V6	2.8 (173)	1988-89	W	KIT	P74006		80	
	CENTURY	V6	2.8 (173)	1984-86	X	KIT	P60488		75	
N	CENTURY	V6	2.8 (173)	1985-92	W	KIT	P54000		72	
	CENTURY	V6	3.1 (183)	1995-96	M	KIT	P74037		82	
	CENTURY	V6	2.8 (173)	1988-89	W	KIT	P74006		80	
N	CENTURY	V6	3.1 (183)	1988-89	M	KIT	P54000		72	
	CENTURY	V6	3.1 (183)	1994-96	M	KIT	P74128		87	
	CENTURY	V6	3.1 (189)	1998-99		MÓDULO	P74792M	2 CC 3 y 4 PTS. = C / R	104	T
	CENTURY	V6	3.1 (189)	2000-03	J	MÓDULO	P74928M		111	T
	CENTURY	V6	3.8 (231)	1998	K	MÓDULO	P74792M	3 CC 3 y 4 PTS. = C / R	104	T
	CHEVY (TBI)	L4	1.4 (86)	1994-01	Z14XE	KIT	P14000	Diseño Carter	72	

T Con Turbina // Con CLEANSCREEN

Aplicaciones por marca para vehículos nacionales

Gasolina

MODELO	CIL.	LTS. (PC)	AÑOS	VIN.	TIPO BOMBA	No. PARTE	OBSERVACIONES	PAG.	NOTA
--------	------	-----------	------	------	------------	-----------	---------------	------	------

Chevrolet / Buick / Oldsmobile

CHEVY (MPFI)	L4	1.6 (97)	1996-05	C16SE	MÓDULO	P90240		134	
CHEVY (MPFI)	L4	1.6 (97)	1996-05	C16SE	KIT	P90241	D / E.O.	134	
CITATION	V6	2.8 (173)	1982-84	X	KIT	P60488		75	
CITATION	V6	2.8 (173)	1988-89	W	KIT	P54000		72	
CITATION	V6	2.8 (173)	1988-89	W	KIT	P74006		80	
CORSA	L4	1.8 (110)	2003-07		MÓDULO	P90220	D / E.O.	134	
CORSA	L4	1.8 (110)	2003-07		KIT	P90221	D / E.O.	134	
CORVETTE	V8	5.7 (350)	1996	P	KIT	P74074		83	
CORVETTE	V8	5.7 (350)	1990-95	J	KIT	P74188		89	
CUTLASS	V6	3.1 (183)	1993-96	M	KIT	P74128		87	
CUTLASS	V6	3.1 (183)	1989-92	T	KIT	P74037		82	
CUTLASS	V6	3.1 (183)	1989-92	T	KIT	P54000		72	
IMPALA	V6	3.4 (207)	2000-03	E	MÓDULO	P74928M		111	T
IMPALA	V6	3.8 (231)	2000-03	K	MÓDULO	P74928M		111	T
MALIBU	L4	2.2 (134)	2004-06	F	MÓDULO	P76221M	Con control de ciclos	126	T
MALIBU	L4	2.2 (134)	2004	F	MÓDULO	P76246M	Con control de ciclos	128	
MALIBU	L4	2.2 (134)	2000-03	J	MÓDULO	P74831M		107	T
MALIBU	L4	2.4 (146)	1998-99	T	MÓDULO	P74781M		103	T
MALIBU	L4	2.4 (146)	1997	T	MÓDULO	P74756M		102	T
MALIBU	V6	3.1 (189)	2000-03	J	MÓDULO	P74831M		107	T
MALIBU	V6	3.1 (189)	1998-99	M, J	MÓDULO	P74781M		103	T
MALIBU	V6	3.1 (189)	1997	M	MÓDULO	P74756M		102	T
MALIBU LT, LTZ	V6	3.5 (211)	2004-06	8	MÓDULO	P76221M	Con control de ciclos	126	T
MALIBU MAXX	V6	3.5 (211)	2004-06	8	MÓDULO	P76246M	Con control de ciclos	128	
MALIBU	V6	3.5 (211)	2000-03	J	MÓDULO	P74831M		107	T
MONTECARLO	V6	3.4 (207)	2000-03	E	MÓDULO	P74928M		111	T
MONTECARLO	V6	3.8 (231)	2000-03	K	MÓDULO	P74928M		111	T
REGAL	V6	3.1 (183)	1994	T	KIT	P74037		82	
REGAL	V6	3.1 (183)	1994	T	KIT	P54000		72	
REGAL	V6	3.1 (183)	1991-93	T	KIT	P74037		82	
REGAL	V6	3.1 (183)	1991-93	T	KIT	P54000		72	
X11	V6	2.8 (173)	1984-86		KIT	P60488		75	

Chrysler / Dodge / Hyundai / Plymouth

300M	V6	3.5 (214)	2000-04	G	MÓDULO	P74823M	CC 4 PTS. = C / R	106	T
300M	V6	3.5 (214)	1999	G	MÓDULO	P74819M	CC 4 PTS. = C / R	106	T
ATOS BY DODGE	L4	1.0 (61)	2001-04	G4HC	MÓDULO	P90600	D / E.O. LINEA ANTERIOR	136	
ATOS BY DODGE	L4	1.1 (67)	2005-07	G4HC	MÓDULO	P90601	D / E.O. 5 pines LINEA NUEVA	136	
CIRRUS	L4	2.4 (143)	2000	X	MÓDULO	P74802M		105	T
CIRRUS	L4	2.4 (143)	1995-97	X	MÓDULO	P74693M		97	T

T Con Turbina // Con CLEANSCREEN

Gasolina

MODELO	CIL.	LTS. (PC)	AÑOS	VIN.	TIPO BOMBA	No. PARTE	OBSERVACIONES	PAG.	NOTA
--------	------	-----------	------	------	------------	-----------	---------------	------	------

Chrysler / Dodge / Hyundai / Plymouth

CIRRUS	V6	2.5 (153)	1998-00	H	MÓDULO	P74802M		105	T
CIRRUS	V6	2.5 (153)	1996-97	H	MÓDULO	P74693M		97	T
CIRRUS	V6	2.5 (153)	1996-97	H	KIT	P90693	NO es un kit Universal	137	
CONCORDE	V6	3.2 (197)	1998-99	J	MÓDULO	P74819M	CC 4 PTS. = C / R	106	T
INTREPID	V6	2.7 (165)	2003-04	R	MÓDULO	P74823M	CC 4 PTS. = C / R	106	T
INTREPID	V6	2.7 (165)	1998-99	R	MÓDULO	P74819M	CC 4 PTS. = C / R	106	T
INTREPID	V6	3.2 (197)	2000-01	J	MÓDULO	P74823M	CC 4 PTS. = C / R	106	T
INTREPID	V6	3.2 (198)	1998-99	J	MÓDULO	P74819M	CC 4 PTS. = C / R	106	T
INTREPID	V6	3.3 (201)	1996-97	T	MÓDULO	P74707M	CC 4 PTS. = S / R	98	T
INTREPID	V6	3.3 (201)	1993-95	T	MÓDULO	P74662M	CC 5 PTS. oo S / R	95	T
INTREPID	V6	3.5 (215)	2003-04	G	MÓDULO	P74823M	CC 4 PTS. = S / R	106	T
INTREPID	V6	3.5 (215)	1996-97	F	MÓDULO	P74707M	CC 4 PTS. = S / R	98	T
INTREPID	V6	3.5 (215)	1993-95	F	MÓDULO	P74662M	CC 5 PTS. oo S / R	95	T
LE BARON	L4	2.2 (135)	1984-90	D	ENSAMBLE	P74502H		92	
LE BARON (TURBO)	L4	2.2 (135)	1989-90	A	KIT	P74083		83	
LE BARON	L4	2.2 (135)	1986-89	D	KIT	P74036		81	
LE BARON	L4	2.5 (153)	1989-90	K	ENSAMBLE	P74502H		92	
LE BARON	L4	2.5 (153)	1986-90	K	KIT	P74036		81	
LE BARON (TURBO)	L4	2.5 (153)	1989-90	J	KIT	P74083		83	
LE BARON	V6	3.0 (183)	1991-95	3	ENSAMBLE	P74629H		93	T
LE BARON	V6	3.0 (183)	1991-95	3	KIT	P90629	NO es un kit Universal	136	
LHS	V6	3.5 (215)	2000-01	G	MÓDULO	P74823M	CC 4 PTS. = S / R	106	T
LHS	V6	3.5 (215)	1999	G	MÓDULO	P74819M	CC 4 PTS. = C / R	106	T
LHS	V6	3.5 (215)	1996-97	F	MÓDULO	P74707M	CC 4 PTS. = S / R	98	T
LHS	V6	3.5 (215)	1994-95	F	MÓDULO	P74662M	CC 5 PTS. = S / R	95	T
NEON	L4	2.0 (122)	2001-05	C, F	MÓDULO	P75027M		115	T
NEON (SOHC y DOHC)	L4	2.0 (122)	2000	C	MÓDULO	P74824M	CC 4 PTS. = C / R	106	T
NEON (Tanque Plástico)	L4	2.0 (122)	1996-99	C	MÓDULO	P74732M	CC 4 PTS. = C / R	100	T
NEON (Tanque Metálico)	L4	2.0 (122)	1995-97	C	MÓDULO	P74676M	CC 4 PTS. = C / R	96	T
NEON SRT-4	L4	2.4 (148)	2003-06	S	MÓDULO	P76227B		126	
NEW YORKER	L4	2.2 (135)	1986-87	E	KIT	P74036		81	
NEW YORKER	L4	2.2 (135)	1986-88	C	ENSAMBLE	P74502H		92	
NEWYORKER (TURBO)	L4	2.2 (135)	1986-88	E	KIT	P74083		83	
NEW YORKER	L4	2.5 (153)	1986-87	K	KIT	P74036		81	
PHANTOM	L4	2.5 (153)	1989-94	K	ENSAMBLE	P74502H		92	
PHANTOM (TURBO)	L4	2.5 (153)	1989-94	J	KIT	P74083		83	
PHANTOM (TURBO)	L4	2.5 (153)	1991-95		ENSAMBLE	P74631	Número Anterior P74631H	94	
PT CRUISER	L4	2.4 (148)	2001-03	B	MÓDULO	P75024M		115	T

T Con Turbina // Con CLEANSCREEN

Aplicaciones por marca para vehículos nacionales

Gasolina

MODELO	CIL.	LTS. (PC)	AÑOS	VIN.	TIPO BOMBA	No. PARTE	OBSERVACIONES	PAG.	NOTA
--------	------	-----------	------	------	------------	-----------	---------------	------	------

Chrysler / Dodge / Hyundai / Plymouth

N	PT CRUISER	L4	2.4 (148)	2003-06	G	KIT	P90676	NO es un kit Universal	137	
N	PT CRUISER	L4	2.4 (148)	2004-07	8	MÓDULO	P76096M		122	T
N	PT CRUISER (TURBO)	L4	2.4 (148)	2004-05	G	MÓDULO	P76097M		122	
	SEBRING	V6	2.5 (153)	1999-01	G	KIT	P76020	CC 4 PTS. = C / R	120	
	SEBRING	V6	2.5 (153)	1999-00	H	MÓDULO	P74802M		105	T
	SEBRING	L4	2.4 (148)	1996-98	X	KIT	P90693	NO es un kit Universal	137	
	SEBRING	V6	2.5 (153)	1996-98	H	KIT	P90693	NO es un kit Universal	137	
	SHADOW	L4	2.2 (135)	1987-90	D	ENSAMBLE	P74502H		92	
	SHADOW	L4	2.2 (135)	1987-90	D	KIT	P74036		81	
	SHADOW	L4	2.5 (153)	1990-94	K	ENSAMBLE	P74629H		93	T
	SHADOW	L4	2.5 (153)	1990-94	K	KIT	P90629	NO es un kit Universal	136	
	SHADOW	L4	2.5 (153)	1988-90	J	KIT	P74036		81	
	SHADOW (TURBO)	L4	2.5 (153)	1991-93	J	ENSAMBLE	P74629H		93	T
	SHADOW (TURBO)	L4	2.5 (153)	1991-93	J	KIT	P90629	NO es un kit Universal	136	
	SHADOW (TURBO)	L4	2.2 (135)	1987-90	C	KIT	P74083		83	
	SHADOW (TURBO)	L4	2.5 (153)	1987-90	J	KIT	P74083		83	
	SPIRIT	L4	2.5 (153)	1991-95	K	ENSAMBLE	P74629H		93	T
	SPIRIT	L4	2.5 (153)	1991-95	K	KIT	P90629	NO es un kit Universal	136	
	SPIRIT	L4	2.5 (153)	1989-90	K	KIT	P74036		81	
	SPIRIT (TURBO)	L4	2.5 (153)	1992-95	J	ENSAMBLE	P74629H		93	T
	SPIRIT (TURBO)	L4	2.5 (153)	1992-95	J	KIT	P90629	NO es un kit Universal	136	
	SPIRIT (TURBO)	L4	2.5 (153)	1989-90	J	KIT	P74083		83	
	SPIRIT (TURBO)	L4	2.5 (153)	1991-95		ENSAMBLE	P74631	Número Anterior P74631H	94	
	STRATUS	L4	2.0 (122)	1998-00	C	MÓDULO	P74802M		105	T
	STRATUS	L4	2.0 (122)	1995-97	C	MÓDULO	P74693M		97	T
	STRATUS	L4	2.0 (122)	1995-97	C	KIT	P90693	NO es un kit Universal	137	
	STRATUS	L4	2.4 (148)	2001-05	G	KIT	P76020	CC 4 PTS. = C / R / No es un kit Universal	120	
	STRATUS	L4	2.4 (148)	2003	X	MÓDULO	P75032M	CC 4 PTS. = C / R	116	T
	STRATUS	L4	2.4 (148)	2003	X, R	MÓDULO	P75033M	Altura del flotador 17 cm. Con línea flexible	116	T
	STRATUS	L4	2.4 (148)	2001-02	X	MÓDULO	P75025M	CC 4 PTS. = C / R	115	T
	STRATUS	L4	2.4 (143)	1998-00	X	MÓDULO	P74802M		105	T
	STRATUS	L4	2.4 (143)	1995-97	X	MÓDULO	P74693M		97	T
	STRATUS	L4	2.4 (143)	1995-97	X	KIT	P90693	NO es un kit Universal	137	
	STRATUS	L4	2.5 (153)	1995-97	H	KIT	P90693	NO es un kit Universal	137	
	VOLARE	L4	2.2 (135)	1982-89		KIT	P60488		75	
	VOLARE	L4	2.5 (153)	1982-89		KIT	P60488		75	
	VERNA	L4	1.5 (90)	2004-05	G4EK	KIT	P72242		79	

T Con Turbina // Con CLEANSCREEN

Gasolina

MODELO	CIL.	LTS. (PC)	AÑOS	VIN.	TIPO BOMBA	No. PARTE	OBSERVACIONES	PAG.	NOTA
--------	------	-----------	------	------	------------	-----------	---------------	------	------

Ford / Lincoln / Mercury

CONTOUR	L4	2.0 (122)	1995-99	3	KIT	P74170		88	
CONTOUR (16 VALV.)	L4	2.0 (122)	1995-96	3	ENSAMBLE	P74689S		97	
CONTOUR	L4	2.0 (122)	1998-99	3	ENSAMBLE	P74859S	Tapa Grande	109	T
CONTOUR	V6	2.5 (153)	1995-99	L	KIT	P74170		88	
CONTOUR	V6	2.5 (155)	1997	L	ENSAMBLE	P74804S		105	
CONTOUR	V6	2.5 (155)	1998-99	G, L	ENSAMBLE	P74859S	Tapa Grande	109	T
COUGAR	V6	3.8 (232)	1984	3	KIT	P74067		83	
COUGAR	V6	3.8 (232)	1989-93	4	ENSAMBLE	P74651S		94	
COUGAR	V8	5.0 (302)	1984	F	KIT	P74067		83	
COUGAR	V8	5.0 (302)	1989-93	T	ENSAMBLE	P74651S		94	
ESCORT GT (16 VALV.)	L4	1.8 (110)	1991-96	B	KIT	P74111		85	
ESCORT WAGON	L4	1.9 (116)	1991-97	J	KIT	P74111		85	
ESCORT	L4	1.9 (116)	1991-96	J	KIT	P74111		85	
ESCORT	L4	1.9 (115)	1987-90	J	KIT	P74065		82	
ESCORT	L4	1.9 (116)	1991-96	J	ENSAMBLE	P74724H		100	
ESCORT	L4	2.0 (122)	1997	3	ENSAMBLE	P74814H		106	
ESCORT	L4	2.0 (122)	1998	P	MÓDULO	P74943M		111	T
ESCORT / ESCORT ZX2	L4	2.0 (122)	1998	3	MÓDULO	P74943M		111	T
ESCORT / ESCORT ZX2	L4	2.0 (122)	1999-02	3	MÓDULO	P74955M		112	T
ESCORT / ESCORT ZX2	L4	2.0 (122)	1998-01	3	KIT	P74199		90	
FOCUS	L4	2.0 (122)	2003-04	3	MÓDULO	P76018M		119	
FOCUS	L4	2.0 (122)	2004	P	KIT	P76230	NO es un kit Universal	126	T
FOCUS	L4	2.0 (122)	2002-03	3, 5	KIT	P76104	NO es un kit Universal	123	T
FOCUS	L4	2.0 (122)	2000-02	3, P	KIT	P74051	Número Anterior P75047	82	
FIESTA IKON	L4	1.6 (95)	2001-06	LIT, LIV	MÓDULO	P90110	No sustituir con el MODULO P90170M	133	
FIESTA IKON	L4	1.6 (95)	2001-06	LIT, LIV	KIT	P90171		133	
FUSION	V6	3.0 (181)	2006-08	1	MÓDULO	P76307M		129	
GHIA	V6	3.0 (183)	1991-94		KIT	P74104		84	
GRAND MARQUIS	V8	4.6 (281)	1997-01	W	KIT	P74172		89	
GRAND MARQUIS	V8	4.6 (281)	1995-96	W	KIT	P74139		87	
GRAND MARQUIS	V8	4.6 (281)	1993-94	W	ENSAMBLE	P74668H		96	
GRAND MARQUIS	V8	4.6 (281)	1992	W	KIT	P74112		85	
GRAND MARQUIS	V8	5.0 (302)	1990-91	F	KIT	P74112		85	
KA	L4	1.6 (97)	2001-06	L1T/L1V	MÓDULO	P90120	D / E.O.	133	
KA	L4	1.6 (97)	2001-06	L1T/L1V	KIT	P90121	D / E.O.	133	

T Con Turbina // Con CLEANSSCREEN

Aplicaciones por marca para vehículos nacionales

Gasolina

MODELO	CIL.	LTS. (PC)	AÑOS	VIN.	TIPO BOMBA	No. PARTE	OBSERVACIONES	PAG.	NOTA
--------	------	-----------	------	------	------------	-----------	---------------	------	------

Ford / Lincoln / Mercury

	LTD	V8	5.0 (302)	1985	F	KIT	P74067		83	
	MARQUIS	V8	5.0 (302)	1984-85	F	KIT	P74067		83	
N	MILAN	V6	3.0 (181)	2006-08	1	MÓDULO	P76307M		129	
	MUSTANG	V8	4.6 (281)	1996-98	X	SOPORTE	P74635H	Número Anterior P74638H	94	
	MUSTANG	V8	5.0 (302)	1994-95	D	KIT	P74119		86	
	MUSTANG	V8	5.0 (302)	1987-93	E	SOPORTE	P74635H	Número Anterior P74638H	94	
	MUSTANG	V8	5.0 (302)	1984-85	F	KIT	P74028		81	
	MYSTIQUE	L4	2.0 (122)	1998-99	3	ENSAMBLE	P74859S	Tapa Grande	109	T
	MYSTIQUE	V6	2.5 (155)	1998-99	G, L	ENSAMBLE	P74859S	Tapa Grande	109	T
	MYSTIQUE	V6	2.5 (153)	1998-99	L	KIT	P74170		88	
	MYSTIQUE	V6	2.5 (155)	1997	L	ENSAMBLE	P74804S		105	
	MYSTIQUE	V6	2.5 (153)	1997	L	KIT	P74178		89	
	MYSTIQUE	V6	2.5 (153)	1995-96	L	ENSAMBLE	P74689S		97	
	MYSTIQUE	V6	2.5 (153)	1995-96	L	KIT	P74170		88	
	SABLE	V6	3.0 (183)	1986-93	U	KIT	P74095		84	
	SABLE	V6	3.0 (183)	2001	U	KIT	P74201		90	
	SABLE	V6	3.0 (183)	1999	U	KIT	P74201		90	
	SABLE	V6	3.0 (183)	1997-98	U	KIT	P74191		90	
	SABLE (12 VALV.)	V6	3.0 (183)	1996	U	ENSAMBLE	P74723H		100	
	SABLE	V6	3.8 (232)	1988-93	4	KIT	P74095		84	
N	TAURUS / TAURUS GUAYIN	V6	3.8 (232)	1988-91	4	ENSAMBLE	P74585S	EFI Sin instrumentos eléctricos	93	
	TAURUS GUAYIN	V6	3.8 (232)	1988-95	4	ENSAMBLE	P74591S	Con instrumentos eléctricos	93	
	THUNDERBIRD (Super Cargado)	V6	3.8 (232)	1992-94	R	ENSAMBLE	P74643S		94	
N	THUNDERBIRD	V6	3.8 (232)	1989-93	4	ENSAMBLE	P74651S		94	
	THUNDERBIRD	V8	5.0 (302)	1991-94	T	KIT	P74025		81	
N	THUNDERBIRD	V8	5.0 (302)	1989-93	T	ENSAMBLE	P74651S		94	
	THUNDERBIRD	V8	5.0 (302)	1984	F	KIT	P74067		83	
	TOPAZ	L4	2.3 (140)	1991-94	X	ENSAMBLE	P74626H		93	
	TOPAZ	L4	2.3 (140)	1991-94	X	KIT	P74104		84	
	TOWN CAR	V8	4.6 (281)	1993-94	W	ENSAMBLE	P74668H		96	

Honda

	ACCORD	L4	2.2 (135)	1994-97	F22B1	KIT	P72192		77	
	ACCORD	L4	2.3 (140)	1998	F23A1	KIT	P72192		77	
	ACCORD	L4	2.3 (140)	1998-02	F23A1	KIT	P76002		118	
	ACCORD	L4	2.3 (140)	1998-02	F23A5	KIT	P76015		119	
	ACCORD	L4	2.4 (144)	2003-04	K24A4	KIT	P76014		119	
	ACCORD	V6	3.0 (181)	1998	J30A1	KIT	P72192		77	

T Con Turbina // Con CLEANSCREEN

Gasolina

MODELO	CIL.	LTS. (PC)	AÑOS	VIN.	TIPO BOMBA	No. PARTE	OBSERVACIONES	PAG.	NOTA
--------	------	-----------	------	------	------------	-----------	---------------	------	------

Honda

	ACCORD	V6	3.0 (181)	1998-02	J30A1	KIT	P76015		119	
	ACCORD	V6	3.0 (181)	1998-02	J30A1	KIT	P76002		118	
N	ACCORD	V6	3.0 (181)	2007-07		MÓDULO	P76380M		130	
	CIVIC	L4	1.5 (92)	1992-95	D15B7	KIT	P72241		79	
	CIVIC	L4	1.6 (97)	2001-04	D17A1	KIT	P76015		119	
	CIVIC EX	L4	1.6 (97)	1997-00	D16Y7	KIT	P76017	4 PTAS. Hecho en Japon	119	
	CIVIC EX	L4	1.6 (97)	1997-00	D16Y7	KIT	P76017	2 y 4 PTS. Hecho USA	119	
	CIVIC	L4	1.6 (97)	1992-96	D16Y7	KIT	P72241		79	
	CIVIC	L4	1.6 (97)	1997-98	D16Y7	KIT	P72192C	Incluye Cedazo	78	
N	CIVIC	L4	1.7 (105)	2003-05	D17A1	KIT	P76215		125	

Mazda

N	MAZDA 3	L4	2.0 (122)	2004-08	LFD	MÓDULO	P76308M		129	
N	MAZDA 6	L4	2.3 (140)	2003-08	MZR	MÓDULO	P76311M		129	
N	MAZDA 6	V6	3.0 (181)	2002-04	MZI	MÓDULO	P76310M		129	

Mitsubishi

	ECLIPSE	L4	2.4 (148)	2000-05	4G64	KIT	P76020	CC 4 PTS. = C / R	120	
	GALANT	L4	2.4 (148)	2001-05	4G64	KIT	P76020	CC 4 PTS. = C / R	120	
	LANCER	L4	2.0 (122)	2002-04	4G64	KIT	P76019		119	
	LANCER	L4	2.4 (148)	2004	4G64	KIT	P76019		119	

Nissan / Infiniti

	200SX	L4	1.6 (97)	1995-98	GA16DE	KIT	P72192A		77	
	200SX	L4	2.0 (122)	1995-98	SR20DE	KIT	P72192A		77	
	ALTIMA	L4	2.4 (146)	1996-99	KA24DE	KIT	P72192		77	
	ALTIMA	L4	2.4 (146)	1996-99	KA24DE	KIT	P72192A		77	
	ALTIMA	L4	2.4 (146)	2000-01	KA24DE	KIT	P76038		121	
N	ALTIMA	V6	2.4 (146)	2002-03	VQ30DE	MÓDULO	P76171M		124	
N	ALTIMA	L4	2.5 (153)	2007-09	QR25DE	MÓDULO	P76400M		130	
N	ALTIMA	V6	3.5 (215)	2007	VQ35DE	MÓDULO	P76400M	Híbrido	130	
N	ALTIMA	V6	3.5 (215)	2007-09	VQ35DE	MÓDULO	P76400M	Híbrido	130	
	INFINITI I30	V6	3.0 (181)	1997-98	VQ30DE	KIT	P72192B		78	
	INFINITI I30	V6	3.0 (181)	2000-01	VQ30DE	KIT	P76035		121	
	MAXIMA	V6	3.0 (181)	1990-94	VG30E	KIT	P72144		77	
	MAXIMA (DOHC, 24 VALV.)	V6	3.0 (181)	1995-98	VQ30DE	KIT	P72192B		78	
	MAXIMA (SOHC)	V6	3.0 (181)	1993-94	VG30DE	KIT	P72250		79	
	MAXIMA (DOHC)	V6	3.0 (181)	1993-94	VE30DE	KIT	P72193A		78	
	MAXIMA (DOHC)	V6	3.0 (181)	1992	VE30DE	KIT	P72144		77	
	MAXIMA (DOHC)	V6	3.0 (181)	1992	VE30DE	KIT	P72201		79	

T Con Turbina // Con CLEANSCREEN

Aplicaciones por marca para vehículos nacionales

Gasolina

MODELO	CIL.	LTS. (PC)	AÑOS	VIN.	TIPO BOMBA	No. PARTE	OBSERVACIONES	PAG.	NOTA
--------	------	-----------	------	------	------------	-----------	---------------	------	------

Nissan / Infiniti

MAXIMA	V6	3.0 (181)	2000-01	VQ30DE	KIT	P76035		121	
MAXIMA	V6	3.5 (215)	2009	VQ35DE	MÓDULO	P76400M	Híbrido	130	
PLATINA	L4	1.6 (97)	2002-06	K4M	MÓDULO	P90420	D / E.O.	134	
PLATINA	L4	1.6 (97)	2002-06	K4M	KIT	P90421	D / E.O.	135	
SENTRA	L4	1.6 (97)	1995-99	GA16DE	KIT	P72192A		77	
SENTRA (16 VALV.)	L4	1.6 (97)	1991-94	GA16DE	KIT	P72230		79	
SENTRA	L4	1.8 (110)	2001-junio-05	QG18DE	MÓDULO	P90430	D / E.O. (2 TUBOS DE SALIDA)	135	
SENTRA	L4	1.8 (110)	2001-junio-05	QG18DE	KIT	P90431	D / E.O. (2 TUBOS DE SALIDA)	135	
TSURU III	L4	1.6 (97)	1993-97	GA16DE	KIT	P72193		78	
TSURU III	L4	1.6 (97)	1997-07	GA16DE	MÓDULO	P90440		135	
TSURU III	L4	1.6 (97)	1997-07	GA16DE	KIT	P90441		135	

Pontiac

GRAND AM	V6	3.1 (189)	1996-98	M	ENSAMBLE	P74712S		99	T
GRAND AM	V6	3.1 (189)	2001-03	J, K	MÓDULO	P74928M		111	T
GRAND PRIX	V6	3.1 (189)	2001-03	J, K	MÓDULO	P74928M		111	T
GRAND PRIX (No Supercargado)	V6	3.1 (189)	1998-00	M	MÓDULO	P74792M	2 CC 3 y 4 PTS. = C / R	104	T
GRAND PRIX (No Supercargado)	V6	3.8 (231)	1998-00	K	MÓDULO	P74792M	3 CC 3 y 4 PTS. = C / R	104	T
SUNFIRE	L4	2.2 (134)	1995	4	MÓDULO	P74688M		97	T
SUNFIRE	L4	2.2 (135)	1996-98	4	ENSAMBLE	P74712S		99	T
SUNFIRE	L4	2.2 (135)	1999	4	MÓDULO	P74781M		103	T
SUNFIRE	L4	2.2 (134)	2000-04	4	MÓDULO	P74831M		107	T
SUNFIRE	L4	2.4 (135)	1996-98	T	ENSAMBLE	P74712S		99	T
SUNFIRE	L4	2.4 (135)	1999	T	MÓDULO	P74781M		103	T
SUNFIRE	L4	2.4 (135)	2000-02	T	MÓDULO	P74831M		107	T

Renault

CLIO II	L4	1.6 (97)	2005-07	K4M 748	MÓDULO	P90550	D / E.O.	135	
CLIO II	L4	1.6 (97)	2005-07	K4M 748	KIT	P90551	D / E.O.	136	
CLIO SPORT	L4	2.0 (122)	2002-05	F4R 730	MÓDULO	P90550	D / E.O.	135	
CLIO SPORT	L4	2.0 (122)	2002-05	F4R 730	KIT	P90551	D / E.O.	136	

Toyota

COROLLA	L4	1.8 (110)	1999-04	1ZZFE	KIT	P76004		118	
MATRIX	L4	1.8 (110)	2003-04	1ZZFE	KIT	P76004		118	
MATRIX	L4	1.8 (110)	2003-04	2ZZGE	KIT	P76004		118	
SOLARA	V6	3.3 (200)	2004	3MZFE	KIT	P76004		118	
YARIS	L4	1.5 (89.5)	2000-05	1NZFE	KIT	P76182		125	

T Con Turbina // Con CLEANSCREEN

Gasolina

MODELO	CIL.	LTS. (PC)	AÑOS	VIN.	TIPO BOMBA	No. PARTE	OBSERVACIONES	PAG.	NOTA
--------	------	-----------	------	------	------------	-----------	---------------	------	------

Volkswagen

N	BEETLE	L4	2.0 (122)	1999-05		MÓDULO	P90030M	MPFI	131	
N	BEETLE	L4	2.0 (122)	1999-05		KIT	P90030		131	
N	BORA	L5	2.5 (153)	2005-07		MÓDULO	P90040M	DOHC 20 valv	131	
N	COMBI	L4	1.8 (110)	1993-99		KIT	P72259		80	
N	DERBY	L4	1.8 (110)	1993-99		KIT	P72259		80	
N	DERBY	L4	1.8 (110)	1994		MÓDULO	P90010M	D/E.O. Num. Anterior P90015	131	
N	GOLF GTI	L4	1.8 (110)	1988-92	JH	KIT	P92105	SDB	138	
N	GOLF II	L4	1.8 (110)	1992-94		KIT	P90011	D/E.O. Num. Anterior P90017	131	
N	GOLF II	L4	1.8 (110)	1992-94		MÓDULO	P90010M	D/E.O. Num. Anterior P90015	131	
N	GOLF	L4	1.8 (110)	1999-06		MÓDULO	P90030M		131	
N	GOLF	L4	1.8 (110)	1999-06		KIT	P90030		131	
N	GOLF A4	L4	2.0 (122)	1999-06		MÓDULO	P90030M	MPFI	131	
N	GOLF A4	L4	2.0 (122)	1999-06		MÓDULO	P90030M	MPFI	131	
N	GOLF A4	L4	2.0 (122)	1999-06		KIT	P90030		131	
N	GOLF VR6	V6	2.8 (173)	1994	AAA	KIT	P72259		80	
N	JETTA	L4	1.8 (110)	1992-94		KIT	P90011	D/E.O. Num. Anterior P90017	131	
N	JETTA	L4	1.8 (110)	1992-94		MÓDULO	P90010M	D/E.O. Num. Anterior P90015	131	
N	JETTA	L4	2.0 (122)	1990-92	9A	KIT	P92024	Sustituye a la P72024	137	
N	JETTA	L4	1.8 (110)	1999-06		MÓDULO	P90030M		131	
N	JETTA	L4	1.8 (110)	1999-06		KIT	P90030		131	
N	JETTA A4	L4	2.0 (122)	1999-06		MÓDULO	P90030M	MPFI	131	
N	JETTA A4	L4	2.0 (122)	1999-06		KIT	P90030		131	
N	JETTA CARAT	L4	2.0 (122)	1990-92	9A	KIT	P92105	Sustituye a la P72105	138	
N	JETTA GLI	L4	2.0 (122)	1990-92	9A	KIT	P92105	SDB	138	
N	JETTA VR6	V6	2.8 (181)	1994	AAA	KIT	P72259		80	
N	JETTA VR6	V6	2.8 (181)	1999-04		MÓDULO	P90030M		131	
N	JETTA VR6	V6	2.8 (181)	1999-04		KIT	P90030		131	
N	LUPO	L4	1.4 (86)	1999-06		MÓDULO	P90030M		131	
N	LUPO	L4	1.4 (86)	1999-06		KIT	P90030		131	
N	PASSAT	L4	1.8 (110)	1998-05	AWM	MÓDULO	P76029M	Turbo 20 valv	120	
N	PASSAT	L4	2.0 (122)	1993	9A	KIT	P72024		75	
N	PASSAT	V6	2.8 (173)	1998-05	ATQ, AMX, AHA	MÓDULO	P76029M		120	
N	POINTER SEDAN	L4	1.8 (110)	1998-05		MÓDULO	P90070	D / E.O.	132	
N	POINTER SEDAN	L4	1.8 (110)	1998-05		KIT	P90071	D / E.O.	132	
N	POLO	L4	1.8 (110)	2003-08	AVY, ARC	MÓDULO	P90090M		132	
N	SEDAN	H4	1.6 (97)	1994-04		MÓDULO	P90050	D / E.O.	132	
N	SEDAN	H4	1.6 (97)	1994-04		KIT	P90051	D / E.O.	132	
N	SHARAN	L4	1.8 (110)	2002-05		MÓDULO	P90030M	TURBO	131	
N	SHARAN	L4	1.8 (110)	2002-05		KIT	P90030	TURBO	131	
N	TOUAREG	V6	3.2 (195)	2004-06	BMV	MÓDULO	P76327M		129	
N	TOUAREG	V6	3.6 (221)	2006-07		MÓDULO	P76327M		129	
N	TOUAREG	V6	4.2 (255)	2004-08		MÓDULO	P76327M		129	

T Con Turbina // Con CLEANSCREEN

Aplicaciones por marca para vehículos nacionales

Gasolina

MODELO	CIL.	LTS. (PC)	AÑOS	VIN.	TIPO BOMBA	No. PARTE	OBSERVACIONES	PAG.	NOTA
--------	------	-----------	------	------	------------	-----------	---------------	------	------

Bombas Electricas Universales (En Línea) 12 Volts

Hi Performace	L4, V6, V8		Todos		KIT	P4594	Gasolina c/sin plomo, diesel	72	
Todos con carburador	L4, V6, V8		Todos		KIT	P60378	Tipo Vaso	73	
Todos con carburador	L4, V6, V8		Todos		KIT	P60108	Electrónica	73	
Todos con carburador	L4, V6, V8		Todos		KIT	P60430	Filtro Doble	73	
Todos con carburador	L4, V6, V8		Todos		KIT	P74019	Cilíndrica	80	
Todos con carburador	L4, V6, V8		Todos		KIT	P74020	Cilíndrica	81	
Todos con carburador	L4, V6, V8		Todos		KIT	P74029	Cilíndrica	81	
Todos con carburador	V6, V8		Todos		KIT	P60432	Tipo Facet Alta Presión	74	
Todos con carburador	L4, V6		Todos		KIT	P60433	Tipo Facet Baja Presión	74	

NOTA : Las Bombas Universales sólo aplican a vehículos con carburador, con bombas en línea.
No se usan dentro del tanque de gasolina.
Éstas bombas son para gasolina y no para líquidos como el Diesel o petróleo

Aplicaciones por marca para camionetas nacionales

Gasolina

MODELO	CIL.	LTS. (PC)	AÑOS	VIN.	TIPO BOMBA	No. PARTE	OBSERVACIONES	PAG.	NOTA	
Chevrolet / Pontiac / Cadillac										
N	AVALANCHE 1500	V8	5.3 (323)	2005-07	Z	MÓDULO	P76232M	TQE de 36 galones	127	T
	AVALANCHE 1500	V8	5.3 (323)	2002-03	T	MÓDULO	P75023M	TBI, WB 130"	114	
	AVALANCHE 1500 TBD	V8	5.3 (323)	2002-03	T	MÓDULO	P74832M	WB = 119" TAG TBD	107	T
N	AVALANCHE 1500	V8	5.3 (323)	2002-08	J, T	KIT	P54901	4 Componentes (filtro, kit, cedazo y arnés)	72	
N	AVALANCHE 1500	V8	5.3 (323)	2002-08	J, T	KIT	P54902	3 Componentes (kit, cedazo y arnés)	72	
N	AVALANCHE 1500	V8	6.0 (364)	2007-08	K, Y	KIT	P54901	4 Componentes (filtro, kit, cedazo y arnés)	72	
N	AVALANCHE 1500	V8	6.0 (364)	2007-08	K, Y	KIT	P54902	3 Componentes (kit, cedazo y arnés)	72	
N	AVALANCHE 2500	V8	8.1 (496)	2007-08	G	KIT	P54901	4 Componentes (filtro, kit, cedazo y arnés)	72	
N	AVALANCHE 2500	V8	8.1 (496)	2007-08	G	KIT	P54902	3 Componentes (kit, cedazo y arnés)	72	
N	AZTEK	V6	3.4 (207)	2001-04	E	MÓDULO	P76179M	A junio de 2004	125	T
N	AZTEK	V6	3.4 (207)	2004-05	E	MÓDULO	P76084M	Desde julio de 2004	122	T
	AZTEK	V6	3.4 (207)	2001-05	E	MÓDULO	P75051M	Sustituye a la P 74967	118	T
	BLAZER	V6	4.3 (262)	1998-03	W	MÓDULO	P74834M	A / F: 8.4cm. Sólo 2 Pts. (Núm Anterior P74827M)	107	T
	BLAZER	V6	4.3 (262)	2003	W	MÓDULO	P74841M	A / F: 15cm. Sólo 2 Pts.	108	T
	BLAZER TCH (4 Pts.)	V6	4.3 (262)	1998-01	W	MÓDULO	P74834M	Altura Flotador 15 cm. (Núm Anterior P74827M)	107	T
	BLAZER SGJ,SFU (4Pts.) Exc. EXPORT.	V6	4.3 (262)	1997-98	W	MÓDULO	P74789M	CODIGOS SGJ, SFU , 4 PUERTAS , EXC, EXPORT.	104	T
	BLAZER	V6	4.3 (262)	1998-03	W	MÓDULO	P74834M	Número Anterior P74827M	107	T
	BLAZER SGK (2 Pts.)	V6	4.3 (262)	1997-01	W	MÓDULO	P74761M	2 CON. DE 3 y 4 = C / R	103	T
	BLAZER	V6	4.3 (262)	1996	W	ENSAMBLE	P74715S	2 PUERTAS	99	T
	BLAZER	V6	4.3 (262)	1996	W	ENSAMBLE	P74716S	4 PUERTAS	100	T
N	BLAZER	V6	4.3 (262)	1999	W	MÓDULO	P74837M	4 PUERTAS , EXPORTACION	107	T
	BLAZER	V6	4.3 (262)	1995	W	KIT	P74074		83	
N	BLAZER	V6	4.3 (262)	1995	W	KIT	P54000		72	
	BRAVADA	L6	4.2 (256)	2002-04	S	MÓDULO	P75053M		118	T
	BRAVADA	V6	4.3 (262)	2000-01	W	MÓDULO	P74834M	Número Anterior P74827M	107	T
	BRAVADA	V6	4.3 (262)	2000-01	W	MÓDULO	P74789M		104	T
	BRAVADA	V6	4.3 (262)	1996	W	ENSAMBLE	P74716S	4 PUERTAS	100	T
	C-10 / C-20 SERIES 1500 / 2500	V6	4.3 (262)	1988-95	Z	ENSAMBLE	P80000S		130	
	C-10 / C-20 SERIES 1500 / 2500	V6	4.3 (262)	1988-95	Z	KIT	P18000	No es un kit Universal	72	
	C-10 / C-20 SERIES 1500 / 2500	V6	4.3 (262)	1997-99		MÓDULO	P74757M		102	T
	C-20 / SERIE 2500	V8	5.7 (350)	1988-95	K	ENSAMBLE	P80000S		130	
	C-20 / SERIE 2500	V8	5.7 (350)	1988-95	K	KIT	P18000	No es un kit Universal	72	
	C-20 / SERIE 2500	V8	7.4 (454)	1988-95	N	ENSAMBLE	P80000S		130	
	C-20 / SERIE 2500	V8	7.4 (454)	1988-95	N	KIT	P18000	No es un kit Universal	72	
	C-1500	V6	4.3 (262)	1996	W	KIT	P74167		88	

Aplicaciones por marca para camionetas nacionales

Gasolina

MODELO	CIL.	LTS. (PC)	AÑOS	VIN.	TIPO BOMBA	No. PARTE	OBSERVACIONES	PAG.	NOTA
--------	------	-----------	------	------	------------	-----------	---------------	------	------

Chevrolet / Pontiac / Cadillac

N	C-1500	V6	4.3 (262)	1996	W	KIT	P54000		72	
	C-1500 PICKUP	V6	4.3 (262)	1996-97	W	ENSAMBLE	P80001S		130	T
	C-1500 PICKUP	V6	4.3 (262)	1997-98	W	MÓDULO	P75055M	Código de etiqueta GFK	118	T
N	C-1500 PICKUP	V8	5.7 (350)	1996-99	R	MÓDULO	P74773M		103	T
	C-2500 PICK-UP	V8	5.7 (350)	1997	R	ENSAMBLE	P80001S		130	T
	C-2500 PICK-UP	V8	5.7 (350)	1995-97	R	KIT	P74167		88	
N	C-2500 PICK-UP	V8	5.7 (350)	1995-97	R	KIT	P54000		72	
	C-2500 PICK-UP	V8	5.7 (350)	1998-00	R	MÓDULO	P75055M	Código de etiqueta GFK	118	T
	C-2500 PICK-UP	V8	7.4 (454)	1997	J	ENSAMBLE	P80001S		130	T
	C-2500 PICK-UP	V8	7.4 (454)	1997	J	ENSAMBLE	P80001S		130	T
	C-2500 PICK-UP	V8	7.4 (454)	1996	J	ENSAMBLE	P80001S		130	T
	C-2500 PICK-UP	V8	7.4 (454)	1994-95	N	ENSAMBLE	P80002S		131	T
	C-3500 PICKUP GFK	V8	5.7 (350)	2000	R	MÓDULO	P75055M	EN, NO EN Tqe.	118	T
	C-3500 PICKUP	V8	5.7 (350)	1999	R	KIT	P74222	EN, NO EN Tqe.	92	
	C-3500 PICKUP	V8	5.7 (350)	1996-97	R	KIT	P74167		88	
N	C-3500 PICKUP	V8	5.7 (350)	1996-97	R	KIT	P54000		72	
	C-3500 PICKUP	V8	5.7 (350)	1997	R	ENSAMBLE	P80001S		130	T
	C-3500 PICKUP	V8	5.7 (350)	1996	R	ENSAMBLE	P80001S		130	T
	C-3500 PICKUP	V8	5.7 (350)	1999-00	R	KIT	P74122	Bomba de transferencia	86	
	C-3500 PICKUP	V8	7.4 (454)	1999-00	R	KIT	P74122	Bomba de transferencia	86	
	C-3500 PICKUP	V8	7.4 (454)	1996-97	J	ENSAMBLE	P80001S		130	T
	C-3500 PICKUP	V8	7.4 (454)	1996-97	N	KIT	P74167		88	
N	C-3500 PICKUP	V8	7.4 (454)	1996-97	N	KIT	P54000		72	
	C-3500 PICKUP	V8	7.4 (454)	1994-95	N	ENSAMBLE	P80002S		131	T
	C-3500 PICKUP	V8	8.1(496)	2000-01	G	MÓDULO	P75014M	Código etiqueta TCU (Núm. Anterior P75017M)	114	T
N	CANYON	L5	3.5 (214)	2006	6	MÓDULO	P76237M	Motores a gas	127	T
N	CANYON	L5	3.5 (214)	2004-05	6	MÓDULO	P76184M		125	T
	CHEVY PICK UP	L4	1.6 (97)	1999-05	C16SE	KIT	P90071	Solo aplica modulo MARWAL, No en modulo BOSCH	132	
N	COLORADO	L4	2.8 (173)	2004-05	8	MÓDULO	P76184M		125	T
N	COLORADO	L5	3.5 (214)	2004-05	6	MÓDULO	P76184M		125	T
N	COLORADO	L4	2.8 (173)	2006	8	MÓDULO	P76237M	Motores a gas	127	T
N	COLORADO	L5	3.5 (214)	2006	6	MÓDULO	P76237M	Motores a gas	127	T
	ESCALADE	V8	5.3 (323)	2002-03	T	MÓDULO	P74832M		107	T
	ESCALADE	V8	5.7 (350)	1999	R	MÓDULO	P74912M		110	T
N	ESCALADE	V8	5.7 (350)	1998-00	R	MÓDULO	P74770M	4 puertas, sin filtro RFI	103	T
	ESCALADE	V8	6.0 (364)	2002-03	N	MÓDULO	P74832M		107	T
	EXPRESS VAN 1500	V6	4.3 (262)	2003	X	MÓDULO	P75019M	C / SP - No aplica a pick up	114	
	EXPRESS VAN 1500	V6	4.3 (262)	2003	W	MÓDULO	P74779M	C / SP	103	T
	EXPRESS VAN 1500 VAY	V6	4.3 (262)	1999-01	W	MÓDULO	P74779M	C / SP	103	T

T Con Turbina // Con CLEANSCREEN

Gasolina

MODELO	CIL.	LTS. (PC)	AÑOS	VIN.	TIPO BOMBA	No. PARTE	OBSERVACIONES	PAG.	NOTA
--------	------	-----------	------	------	------------	-----------	---------------	------	------

Chevrolet / Pontiac / Cadillac

N	EXPRESS VAN 1500	V6	4.3 (262)	2004	X	MÓDULO	P76086M		122	T
N	EXPRESS VAN 2500	V8	5.3 (323)	2003-08	J, T	KIT	P54902	3 Componentes (kit, cedazo y arnés)	72	
	EXPRESS VAN 2500 VAY	V8	5.7 (350)	1999-02	R	MÓDULO	P74779M	C / SP (Núm. Anterior P74828M)	103	T
	EXPRESS VAN 2500 VAZ	V8	5.7 (350)	1999-02	R	MÓDULO	P74778M		103	T
N	EXPRESS VAN 2500	V8	6.0 (364)	2005-08	K, Y	KIT	P54901	4 Componentes (filtro, kit, cedazo y arnés)	72	
	EXPRESS VAN 3500	V8	5.7 (350)	2001-02	R	MÓDULO	P74978M	DOS CON.	113	T
	EXPRESS VAN 3500	V8	5.7 (350)	2001-02	R	MÓDULO	P74979M	UN CON.	113	T
	EXPRESS VAN 3500	V8	5.7 (350)	1999-02	R	MÓDULO	P74915M	Sólo TQE de 55 galones	111	T
	EXPRESS VAN 3500	V8	5.7 (350)	1999-02	R	MÓDULO	P74916M	SIN CONEXIÓN RAPIDA	111	T
	G-3500 VAN	V8	5.7 (350)	1998	R	MÓDULO	P74914M	Sólo TQE de 35 galones	110	T
	G-3500 VAN	V8	5.7 (350)	1997-98	R	MÓDULO	P74915M	Sólo TQE de 55 galones	111	T
	G-20 2500 PICK UP	V6	4.3 (262)	1997-99		MÓDULO	P74778M		103	T
	G-20 2500 PICK UP	V8	5.7 (350)	1987-96	K	KIT	P74000		80	
	G-20 2500 VAN	V8	5.7 (350)	1998	R	MÓDULO	P74779M	C / SP (Núm. Anterior P74828M)	103	T
	G-25 / 2500 VAN	V8	5.7 (350)	1998	R	MÓDULO	P74779M	C / SP (Núm. Anterior P74828M)	103	T
	G-30 3500 PICK UP	V8	5.7 (350)	1987-96	K	KIT	P74000		80	
	G-30 VAN	V8	5.7 (350)	1997	R	MÓDULO	P74915M	Sólo TQE de 55 galones	111	T
	G-35	V8	5.7 (350)	1998	R	MÓDULO	P74914M	Sólo TQE de 35 galones	110	T
	G-35 / 3500 VAN	V8	5.7 (350)	1998-99	R	MÓDULO	P74779M	C / SP (Núm. Anterior P74828M)	103	T
	G-35 / 3500 VAN	V8	5.7 (350)	1998	R	MÓDULO	P74916M	SIN CONEXIÓN RAPIDA	111	T
N	HUMMER H2	V8	6.0 (364)	2004-06	U	MÓDULO	P76147M	C TANQUE DE 35 GALONES	124	T
	K1500 PICKUP	V6	4.3 (262)	1997	W	ENSAMBLE	P80001S		130	T
	K1500 PICKUP	V6	4.3 (262)	1996	W	ENSAMBLE	P80001S		130	T
	K1500 PICKUP	V8	5.0 (305)	1997	M	ENSAMBLE	P80001S		130	T
	K1500 PICKUP	V8	5.4 (350)	1997		ENSAMBLE	P80001S		130	T
	K1500 PICKUP	V8	5.0 (305)	1996	M	ENSAMBLE	P80001S		130	T
	K1500 PICKUP	V8	5.7 (350)	1996	R	ENSAMBLE	P80001S		130	T
N	K1500 PICKUP	V8	5.7 (350)	1997-99	R	MÓDULO	P74773M		103	T
	K1500 PICKUP	V6	4.3 (262)	1997	W	ENSAMBLE	P80001S		130	T
	K1500 PICKUP	V6	4.3 (262)	1986	N	ENSAMBLE	P80001S		130	T
	K1500 PICKUP	V8	5.7 (350)	1997	R	ENSAMBLE	P80001S		130	T
	K1500 PICKUP	V8	5.0 (305)	1996	M	ENSAMBLE	P80001S		130	T
	K2500 PICKUP	V8	5.7 (350)	1997	R	ENSAMBLE	P80001S		130	T
	K2500 PICKUP	V8	7.4 (454)	1997	J	ENSAMBLE	P80001S		130	T
	K2500 PICKUP	V8	7.4 (454)	1996	J	ENSAMBLE	P80001S		130	T

T Con Turbina // Con CLEANSCREEN

Aplicaciones por marca para camionetas nacionales

Gasolina

MODELO	CIL.	LTS. (PC)	AÑOS	VIN.	TIPO BOMBA	No. PARTE	OBSERVACIONES	PAG.	NOTA
--------	------	-----------	------	------	------------	-----------	---------------	------	------

Chevrolet / Pontiac / Cadillac

	KODIAK	V8	8.1 (496)	2000-01	G	MÓDULO	P75014M		114	T
	LUMINA	V6	3.1 (183)	1990-96	T	KIT	P74037		82	
N	LUMINA	V6	3.1 (183)	1990-96	T	KIT	P54000		72	
	LUMINA	V6	3.1 (189)	1999	M	MÓDULO	P74960M		112	T
	LUMINA	V6	3.1 (189)	2000-01	J	MÓDULO	P74966M		112	T
	LUMINA APV	V6	3.8 (232)	1992-95	L	KIT	P74037		82	
N	LUMINA APV	V6	3.8 (232)	1992-95	L	KIT	P54000		72	
N	MONTANA	V6	3.5 (214)	2005-06	L	MÓDULO	P76233M	Sin cabina extendida	127	T
N	MONTANA	V6	3.5 (214)	2005-09	L	MÓDULO	P76234M	Con cabina extendida	127	T
	JIMMY	V6	4.3 (262)	1996	W	ENSAMBLE	P74716S	4 PUERTAS	100	T
	P-20, 2500 CHASIS, 2500 PICK UP	V8	5.7 (350)	1987-89	K	KIT	P74000		80	
	P-350 CHASIS CABINA / MICROBUS	V8	5.7 (350)	1987-96	K	KIT	P74000		80	
	S-10	L4	2.2 (135)	2000-03	5	MÓDULO	P74990M		113	
	S-10	L4	2.2 (135)	1997-00	4	MÓDULO	P74755M		102	T
	S-10	L4	2.2 (134)	1996	4	ENSAMBLE	P74717S		100	T
N	S-10	L4	2.2 (135)	1994-95	4	KIT	P74037		82	
	S-10	L4	2.2 (135)	1994-95	4	KIT	P54000		72	T
	S-10	V6	4.3 (262)	2003-04	X	MÓDULO	P74902M		110	T
	S-10	V6	4.3 (262)	2002	W	MÓDULO	P74902M		110	T
	S-10	V6	4.3 (262)	2000-01	W	MÓDULO	P75006M		114	T
N	S-10	V6	4.3 (262)	1996	W, X	ENSAMBLE	P74714S		99	T
N	S-10	V6	4.3 (262)	1997-99	W, X	MÓDULO	P74760M		102	T
	SERIES C-10 / 1500	V6	4.3 (262)	1997-99		MÓDULO	P74757M	2 CON. DE 3 y 4 = C / R	102	T
	SERIES C-20 / 2500	V6	4.3 (262)	1997-98	W	MÓDULO	P74757M	2 CON. DE 3 y 4 = C / R	102	T
	SERIES C-20 / 2500	V8	5.0 (302)	1998-99	M	MÓDULO	P74757M	2 CON. DE 3 y 4 = C / R	102	T
	SERIES C-20 / 2500	V8	5.7 (350)	1998-99	R	MÓDULO	P74757M	2 CON. DE 3 y 4 = C / R	102	T
	SERIES C-20 / 2500	V8	7.4 (454)	1998-99	J	MÓDULO	P74757M	2 CON. DE 3 y 4 = C / R	102	T
	SERIES C-30 / 3500	V8	5.7 (350)	1998-99	R	MÓDULO	P74757M	2 CON. DE 3 y 4 = C / R	102	T
	SERIES C-30 / 3500	V8	7.4 (454)	1998-99	J	MÓDULO	P74757M	2 CON. DE 3 y 4 = C / R	102	T
	SIERRA	V6	4.3 (262)	2002-03	W	MÓDULO	P75014M	S / cama levantada 2" (Núm. Anterior P75017M)	114	T
N	SIERRA 1500	V6	4.3 (262)	2004	X	MÓDULO	P76243M	Sin sistema EVAP,/ sin sistema de combustible robusto K53	127	
N	SIERRA 1500	V6	4.3 (262)	2004	X	MÓDULO	P76245M	Chasis comercia con tanque de EVAP	128	T
	SIERRA 1500	V6	4.3 (262)	1999-03	W	MÓDULO	P75014M	Número Anterior P75017M	114	T
	SIERRA 1500	V6	4.8 (294)	2001	V	MÓDULO	P75014M	Número Anterior P75017M	114	T
N	SIERRA 3500	V8	6.0 (364)	2004	U	MÓDULO	P76245M		128	T

T Con Turbina // Con CLEANSCREEN

Gasolina

MODELO	CIL.	LTS. (PC)	AÑOS	VIN.	TIPO BOMBA	No. PARTE	OBSERVACIONES	PAG.	NOTA
--------	------	-----------	------	------	------------	-----------	---------------	------	------

Chevrolet / Pontiac / Cadillac

N	SIERRA 3500	V8	8.1 (496)	2004	G	MÓDULO	P76245M	Chasis comercial , con tanque de EVAP	128	T
	SIERRA DELANI	V8	6.0 (364)	2002-03	U	MÓDULO	P75014M	Número Anterior P75017M	114	T
	SILHOUETTE	V6	3.4 (207)	2002-04	E	MÓDULO	P74900M	Tipo chasis extendido	110	
	SILHOUETTE	V6	3.4 (207)	2002-04	E	MÓDULO	P74989M	Tipo chasis convencional	113	
	SILHOUETTE	V6	3.4 (207)	2001	E	MÓDULO	P74987M	Tipo chasis extendido	113	T
	SILHOUETTE	V6	3.4 (207)	2001	E	MÓDULO	P74988M	Tipo chasis convencional	113	T
N	SILHOUETTE	V6	3.4 (207)	1997	E	MÓDULO	P74790M		104	T
	SILHOUETTE	V6	3.8 (232)	1992-95	L	KIT	P74037		82	
N	SILHOUETTE	V6	3.8 (232)	1992-95	L	KIT	P54000		72	
N	SILVERADO 1500 PICK UP	V6	4.3 (262)	2001-04	W, X	MÓDULO	P76223M	Con sistema EVAP/ sin sistema de combustible robusto K53	126	T
N	SILVERADO 1500 PICK UP	V6	4.3 (262)	2004	X	MÓDULO	P76243M	Sin sistema EVAP/ sin sistema de combustible robusto K53	127	
	SILVERADO 1500 PICK UP	V6	4.3 (262)	2003	X	MÓDULO	P75014M	Número Anterior P75017M	114	T
	SILVERADO 1500 PICK UP	V6	4.3 (262)	1999-01	W	MÓDULO	P75014M	S / cama levantada 2" (Núm. Anterior P75017M)	114	T
	SILVERADO 1500 PICK UP TCF	V6	4.3 (262)	1999-03	W	MÓDULO	P74835M		107	T
	SILVERADO 1500 PICK UP	V6	4.3 (262)	1999-02	W	MÓDULO	P75014M	Número Anterior P75017M	114	T
	SILVERADO 1500 PICK UP	V6	4.3 (262)	2003	X	MÓDULO	P75014M	Número Anterior P75017M	114	T
	SILVERADO 1500 PICK UP	V8	4.8 (298)	1999-01	V	MÓDULO	P75014M	Número Anterior P75017M	114	T
N	SILVERADO 1500 PICK UP	V8	5.3 (323)	2005-07	Z	MÓDULO	P76232M	TQE de 32 galones	127	T
N	SILVERADO 1500 PICK UP	V8	6.0 (364)	2005-07	U	MÓDULO	P76242M	Sin sistema EVAP	127	T
	SILVERADO 2500 PICK UP	V8	5.3 (323)	2005-06	T	MÓDULO	P75014M	Número Anterior P75017M	114	T

T Con Turbina // Con CLEANSCREEN

Aplicaciones por marca para camionetas nacionales

Gasolina

MODELO	CIL.	LTS. (PC)	AÑOS	VIN.	TIPO BOMBA	No. PARTE	OBSERVACIONES	PAG.	NOTA
--------	------	-----------	------	------	------------	-----------	---------------	------	------

Chevrolet / Pontiac / Cadillac

SILVERADO 2500 PICK UP	V8	5.3 (323)	2002-03	T	MÓDULO	P75014M	Número Anterior P75017M	114	T
SILVERADO 2500 PICK UP	V8	5.3 (323)	2002	T	MÓDULO	P75014M	Número Anterior P75017M	114	T
SILVERADO 2500 PICK UP	V8	5.3 (323)	2003	T	MÓDULO	P74835M		107	T
SILVERADO 2500 PICK UP	V8	5.3 (323)	1999-00	T	MÓDULO	P75014M	Número Anterior P75017M	114	T
SILVERADO 2500 PICK UP	V8	6.0 (364)	2005-07	U	MÓDULO	P76242M	Con sistema EVAP	127	T
SILVERADO 2500HD	V8	8.1 (496)	2005-07	G	MÓDULO	P76242M	Con sistema EVAP	127	T
SILVERADO 3500 PICK UP	V8	6.0 (364)	2001-02	U	MÓDULO	P75014M	Código Etiqueta TCU (Núm. Anterior P75017M)	114	T
SILVERADO 3500 PICK UP	V8	6.0 (364)	2004	U	MÓDULO	P76245M	Chasis comercial, con tanque de EVAP	128	T
SILVERADO 3500 PICK UP	V8	6.0 (364)	2005-07	U	MÓDULO	P76242M	Con sistema EVAP	127	T
SILVERADO 3500 PICK UP	V8	8.1 (496)	2001	G	MÓDULO	P74931M			T
SILVERADO 3500 PICK UP	V8	8.1 (496)	2004	G	MÓDULO	P76245M	Chasis comercial, con tanque de EVAP	128	T
SILVERADO 3500 PICK UP	V8	8.1 (496)	2005-07	G	MÓDULO	P76242M	Con sistema EVAP	127	T
SILVERADO	V8	5.7 (350)	1992-95	K	KIT	P74000		80	
SILVERADO	V8	6.0 (364)	1999-03	U	MÓDULO	P74835M		107	T
SILVERADO	V8	6.0 (364)	1999-01	U	MÓDULO	P75014M	Número Anterior P75017M	114	T
SILVERADO	V8	8.1 (496)	2001	G	MÓDULO	P75014M	Número Anterior P75017M	114	T
SUBURBAN	V8	5.7 (350)	1992-95	K	KIT	P74000		80	
TAHOE	V8	5.7 (350)	1998-00	R	MÓDULO	P74770M	4 puertas, sin filtro RFI	103	T
TAHOE	V8	5.7 (350)	1998-99	R	MÓDULO	P74773M	2 puertas	103	T
TERRAZA	V6	3.5 (214)	2005-07	L	MÓDULO	P76233M	Sin cabina extendida	127	T
TERRAZA	V6	3.5 (214)	2005-06	L	MÓDULO	P76234M	Con cabina extendida	127	T
TORNADO	L4	1.8 (110)	2003-07		MÓDULO	P90220	D / E.O.	134	
TORNADO	L4	1.8 (110)	2003-07		KIT	P90221	D / E.O.	134	
TRACKER (GEO JEEP)	L4	1.6 (97)	2000	6	KIT	P76001		118	
TRACKER (GEO JEEP)	L4	1.6 (97)	1998-99	6	KIT	P72237		79	
TRACKER (GEO JEEP)	L4	1.6 (97)	1996-97	6	KIT	P72192		77	
TRACKER (GEO JEEP)	L4	2.0 (122)	2000-03	C	KIT	P76001		118	
TRACKER (GEO JEEP)	V6	2.5 (153)	2001-04	4	KIT	P76001		118	

T Con Turbina // Con CLEANSCREEN

Gasolina

MODELO	CIL.	LTS. (PC)	AÑOS	VIN.	TIPO BOMBA	No. PARTE	OBSERVACIONES	PAG.	NOTA
--------	------	-----------	------	------	------------	-----------	---------------	------	------

Chevrolet / Pontiac / Cadillac

	TRAILBLAZER	L6	4.2 (256)	2000-04	S	MÓDULO	P75053M		118	T
	TRAILBLAZER	L6	4.2 (256)	2005-07	S	MÓDULO	P76217M	LS, LT	126	T
	TRAILBLAZER	V8	5.3 (323)	2003-04	P	MÓDULO	P75053M		118	T
	TRAILBLAZER	V8	5.3 (325)	2006-07	M	MÓDULO	P76217M	LS, LT	126	T
	TRAILBLAZER	V8	6.0 (364)	2006-07	H	MÓDULO	P76217M		126	T
N	UPLANDER	V6	3.5 (214)	2005-06	L	MÓDULO	P76233M	Sin cabina extendida	127	T
N	UPLANDER	V6	3.5 (214)	2005-08	L	MÓDULO	P76234M	Con cabina extendida	127	T
	VENTURE	V6	3.4 (207)	2002-05	E	MÓDULO	P74900M	Tipo chasis extendido	110	
	VENTURE	V6	3.4 (207)	2002-04	E	MÓDULO	P74989M	Tipo chasis convencional	113	
	VENTURE	V6	3.4 (207)	2001	E	MÓDULO	P74987M	A / F: 18cm. CON B / M	113	T
	VENTURE	V6	3.4 (207)	2001	E	MÓDULO	P74988M	A / F: 16cm. SIN B / M	113	T
	VENTURE	V6	3.4 (207)	1998-00	E	MÓDULO	P74794M		104	T
N	VENTURE	V6	3.4 (207)	1997	E	MÓDULO	P74790M	Larga MPFI W.B. 112 "	104	T
	VENTURE	V6	3.4 (207)	1997	E	MÓDULO	P74791M	Larga MPFI	104	T
N	YUKON	V8	5.7 (350)	1998-00	R	MÓDULO	P74770M	4 puertas, sin filtro RFI	103	T

Chrysler / Dodge

	CAMION B150	V6	3.9 (239)	1992-95	X	MÓDULO	P74658M	CON. 5 oo C / R	95	
	DAKOTA	L4	2.5 (153)	1991-95	G	MÓDULO	P74654M	Con sistema de retorno	95	
	DAKOTA	L4	2.5 (153)	1994-96	P	MÓDULO	P74675M	CON. 5 oo C / R Diseño CARTER	96	
	DAKOTA	L4	2.5 (153)	1996	P	MÓDULO	P74711M	Diseño WALBRO	99	
	DAKOTA 15 GAL	L4	2.5 (153)	1997-02	P	MÓDULO	P74739M		101	
	DAKOTA 22 GAL	L4	2.5 (153)	1997-02	P	MÓDULO	P74738M		101	T
	DAKOTA	V6	3.9 (239)	1991-95	X	MÓDULO	P74654M	Con sistema de retorno	95	
	DAKOTA	V6	3.9 (239)	1994-96	X	MÓDULO	P74675M	CON. 5 oo C / R Diseño CARTER	96	
	DAKOTA	V6	3.9 (239)	1996	X	MÓDULO	P74711M	Diseño WALBRO	99	
	DAKOTA 15 GAL	V6	3.9 (239)	1997-04	K	MÓDULO	P74739M		101	
	DAKOTA 22 GAL	V6	3.9 (239)	1997-04	K	MÓDULO	P74738M		101	T
	DAKOTA	V8	5.2 (318)	1994-96	T	MÓDULO	P74675M	CON. 5 oo C / R Diseño CARTER	96	
	DAKOTA	V8	5.2 (318)	1996	T	MÓDULO	P74711M	Diseño WALBRO	99	
	DAKOTA	V8	5.2 (318)	1991-95	Y	MÓDULO	P74654M	Con sistema de retorno	95	
	DAKOTA 15 GAL	V8	4.7 (285)	1997-04	K	MÓDULO	P74739M		101	
	DAKOTA 22 GAL	V8	4.7 (285)	1997-04	K	MÓDULO	P74738M		101	T
	DAKOTA 15 GAL	V8	5.2 (318)	1997-99	Y	MÓDULO	P74739M		101	
	DAKOTA 22 GAL	V8	5.2 (318)	1997-99	Y	MÓDULO	P74738M		101	T
	DAKOTA 15 GAL	V8	5.9 (360)	1997-00	Z	MÓDULO	P74739M		101	
	DAKOTA 22 GAL	V8	5.9 (360)	1997-00	Z	MÓDULO	P74738M		101	T
	DURANGO	V8	4.7 (285)	2000-03	N	MÓDULO	P74803M		105	T
	DURANGO	V8	5.2 (318)	1998-00	Y	MÓDULO	P74803M	CON. 4 = C / R	105	T

T Con Turbina // Con CLEANSCREEN

Aplicaciones por marca para camionetas nacionales

Gasolina

MODELO	CIL.	LTS. (PC)	AÑOS	VIN.	TIPO BOMBA	No. PARTE	OBSERVACIONES	PAG.	NOTA
--------	------	-----------	------	------	------------	-----------	---------------	------	------

Chrysler / Dodge

DURANGO	V8	5.9 (360)	1998-03	Z	MÓDULO	P74803M	CON. 4 = C / R	105	T
GRAN VOYAGER	L4	2.4 (148)	1996-97	B	MÓDULO	P74706M		98	T
GRAN VOYAGER	V6	3.0 (181)	1996-00	3	MÓDULO	P74706M		98	T
GRAN VOYAGER	V6	3.3 (201)	1996-00	R	MÓDULO	P74706M		98	T
GRAN VOYAGER	V6	3.3 (201)	1991-95	R	MÓDULO	P74634M	Tracción Delantera (FWD)	94	T
GRAN VOYAGER	V6	3.3 (201)	1991-95	R	KIT	P90634	No es un kit Universal	136	
GRAN VOYAGER	V6	3.3 (201)	1991-95		MÓDULO	P74656M	solo aplica para 5 pines	95	
GRAN VOYAGER	V6	3.8 (230)	1999	L	MÓDULO	P74706M		98	T
GRAN VOYAGER	V6	3.8 (230)	1994-95	L	MÓDULO	P74634M	Tracción Delantera (FWD)	94	T
GRAN VOYAGER	V6	3.8 (230)	1994-95	L	KIT	P90634	No es un kit Universal	136	
MICROBUS	V8	5.9 (360)	1988	W	KIT	P74082		83	
MICROBUS	V8	5.9 (360)	1990-93	Z	MÓDULO	P74653M	CON. 5 oo S / R	94	
PT CRUISER	L4	2.4 (148)	2001-03	B	MÓDULO	P75024M		115	T
PT CRUISER	L4	2.4 (148)	2003-06	G	KIT	P90676		137	
PACIFICA	V6	3.5 (212)	2004-06	4	MÓDULO	P76254M		128	
PACIFICA	V6	3.8 (231)	2004-06	L	MÓDULO	P76254M		128	
PICK UP	V8	5.9 (360)	1990-93	Z	MÓDULO	P74653M	CON. 5 oo S / R	94	
RAM 1500	V6	3.7 (230)	2004-07	K	MÓDULO	P76259M	TQE de 26 galones, Cama Larga, conectores planos Blanca	128	
RAM 1500	V8	3.7 (230)	2004-05	N	MÓDULO	P76260M	Cama Corta y conectores de Aguja Base Verde	128	
RAM 1500	V8	4.7 (285)	2004-07	N	MÓDULO	P76259M	TQE de 26 galones, todas las versiones	128	
RAM 1500	V8	5.7 (350)	2004-07	2	MÓDULO	P76259M	TQE de 26 galones, todas las versiones	128	
RAM 1500 (35 Gal.)	V6	3.7 (230)	2002-03	K	MÓDULO	P75029M		115	T
RAM 1500 (26 Gal.)	V6	3.7 (230)	2002-03	K	MÓDULO	P75028M		115	T
RAM 1500	V6	3.9 (239)	1996-01	X	KIT	P90771	TQE de 26 galones	137	
RAM 1500 (2WD, 4WD STD. Cabina)	V6	3.9 (239)	1998-01	X	MÓDULO	P74734M	CON. 4 = C / R	101	
RAM 1500 (CLUB CAB Tqe./ 26 Gal. 2 / 4WD)	V6	3.9 (239)	1998-01	X	MÓDULO	P74801M	CON. 4 = C / R	105	T
RAM 1500 (CLUB CAB Tqe./ 26 Gal. 2 / 4WD)	V6	3.9 (239)	1998-01	X	KIT	P90771	No es un kit Universal	137	
RAM 1500 (CLUB CAB Tqe./ 35 Gal. 2 / 4WD)	V6	3.9 (239)	1998-01	X	MÓDULO	P74735M	CON. 4 = C / R	101	T
RAM 1500 (2WD, 4WD 26 / 35 Gal.)	V6	3.9 (239)	1996-97	X	MÓDULO	P74710M	CON. 4 = C / R	99	
RAM 1500 (2WD, 4WD 26 / 35 Gal. (USA))	V6	3.9 (239)	1996-97	X	MÓDULO	P74710M	CON. 4 = C / R	99	

T Con Turbina // Con CLEANSCREEN

Gasolina

MODELO	CIL.	LTS. (PC)	AÑOS	VIN.	TIPO BOMBA	No. PARTE	OBSERVACIONES	PAG.	NOTA
--------	------	-----------	------	------	------------	-----------	---------------	------	------

Chrysler / Dodge

RAM 1500 (2WD, 4WD M tipo Carter)	V6	3.9 (239)	1995	Z	MÓDULO	P74682M	CON. 4 = C / R	96	
RAM 1500 (2WD, 4WD M tipo Carter)	V6	3.9 (239)	1994	Y	MÓDULO	P74673M	CON. 5 oo C / R	96	
RAM 1500 (2WD, 4WD M tipo Walbro)	V6	3.9 (239)	1995	X	MÓDULO	P74695M	CON. 4 = C / R	97	
RAM 1500 (M.P.F.I. / MEX)	V6	3.9 (239)	1996	X	MÓDULO	P74701M	CON. 6 = C / R	98	
RAM 1500 (T.B.I.)	V6	3.9 (239)	1996	Y	MÓDULO	P74702M	CON. 6 = S / R	98	
RAM 1500 (1/2 TON)	V8	5.2 (318)	2001-03	Y	MÓDULO	P75030M		116	T
RAM 1500 (1/2 TON)	V8	5.9 (360)	2001-03	Z	MÓDULO	P75030M		116	T
RAM 2500 (26 Galones)	V8	4.7 (285)	2002-03	N	MÓDULO	P75028M		115	T
RAM 2500 (26 Galones)	V8	4.7 (285)	2004-05	N	MÓDULO	P76260M	Cama Corta y conectores de Aguja Base Verde	128	
RAM 2500 (35 Galones)	V8	4.7 (285)	2002-03	N	MÓDULO	P75029M		115	T
RAM 2500 (26 Galones)	V8	5.9 (360)	1998-01	Z	MÓDULO	P75028M		115	T
RAM 2500 (35 Galones)	V8	5.9 (360)	1998-01	Z	MÓDULO	P75029M		115	T
RAM 2500 (2WD, 4WD STD. Cabina)	V8	5.2 (318)	1998-02	W	MÓDULO	P74734M	CON. 4 = C / R	101	
RAM 2500 (2WD, 4WD STD. Cabina)	V8	5.9 (360)	1998-02	W	MÓDULO	P74734M	CON. 4 = C / R	101	
RAM 2500 (CLUB CAB Tqe. / 26 Gal. 2 / 4WD)	V8	5.2 (318)	1998-01	X	MÓDULO	P74801M	CON. 4 = C / R	105	T
RAM 2500 (CLUB CAB Tqe. / 26 Gal. 2 / 4WD)	V8	5.2 (318)	1998-01	X	KIT	P90771	No es un kit Universal	137	
RAM 2500 (CLUB CAB Tqe. / 26 Gal. 2 / 4WD)	V8	5.9 (360)	1998-01		MÓDULO	P74801M	CON. 4 = C / R	105	T
RAM 2500 (CLUB CAB Tqe. / 26 Gal. 2 / 4WD)	V8	5.9 (360)	1998-01	X	KIT	P90771	No es un kit Universal	137	
RAM 2500 (CLUB CAB Tqe. / 35 Gal. 2 / 4WD)	V8	5.2 (318)	1998-01	X	MÓDULO	P74735M	CON. 4 = C / R	101	T

T Con Turbina // Con CLEANSCREEN

Aplicaciones por marca para camionetas nacionales

Gasolina

MODELO	CIL.	LTS. (PC)	AÑOS	VIN.	TIPO BOMBA	No. PARTE	OBSERVACIONES	PAG.	NOTA
--------	------	-----------	------	------	------------	-----------	---------------	------	------

Chrysler / Dodge

RAM 2500 (CLUB CAB Tqe. / 35 Gal. 2 / 4WD)	V8	5.9 (360)	1998-01		MÓDULO	P74735M	CON. 4 = C / R	101	T
RAM 2500 (2 / 4WD 26 / 35 Gal.)	V8	5.2 (318)	1996-97	X	MÓDULO	P74710M	CON. 4 = C / R	99	
RAM 2500 (2 / 4WD 26 / 35 Gal.)	V8	5.9 (360)	1996-97	X	MÓDULO	P74710M	CON. 4 = C / R	99	
RAM 2500 (2 / 4WD 26 / 35 Gal. / USA)	V8	5.2 (318)	1996-97	X	MÓDULO	P74710M	CON. 4 = C / R	99	
RAM 2500 (2 / 4WD 26 / 35 Gal. / USA)	V8	5.9 (360)	1996-97	X	MÓDULO	P74710M	CON. 4 = C / R	99	
RAM 2500 (2 / 4WD M tipo Carter)	V8	5.2 (318)	1995	Z	MÓDULO	P74682M	CON. 4 = C / R	96	
RAM 2500 (2 / 4WD M tipo Carter)	V8	5.9 (360)	1995	Z	MÓDULO	P74682M	CON. 4 = C / R	96	
RAM 2500 (2 / 4WD M tipo Carter)	V8	5.2 (318)	1994	Y	MÓDULO	P74673M	CON. 5 oo C / R	96	
RAM 2500 (2 / 4WD M tipo Carter)	V8	5.9 (360)	1994	Y	MÓDULO	P74673M	CON. 5 oo C / R	96	
RAM 2500 (2 / 4WD M tipo Walbro)	V8	5.2 (318)	1995	X	MÓDULO	P74695M	CON. 4 = C / R	97	
RAM 2500 (2 / 4WD M tipo Walbro)	V8	5.9 (360)	1995	X	MÓDULO	P74695M	CON. 4 = C / R	97	
RAM 2500 (M.P.F.I. / MEX)	V8	5.2 (318)	1996	X	MÓDULO	P74701M	CON. 6 = C / R	98	
RAM 2500 (M.P.F.I. / MEX)	V8	5.9 (360)	1996	X	MÓDULO	P74701M	CON. 6 = C / R	98	
RAM 2500 (T.B.I.)	V8	5.2 (318)	1996	Y	MÓDULO	P74702M	CON. 6 = S / R	98	
RAM 2500 (T.B.I.)	V8	5.9 (360)	1996	Y	MÓDULO	P74702M	CON. 6 = S / R	98	
RAM 3500	L6	5.9 (360)	1999-03	6, D	KIT	P74213	Motor Cummins	91	
RAM 3500 (2 / 4WD)	V8	5.9 (360)	1997	Z, 5	MÓDULO	P74710M	CON. 4 = C / R	99	
RAM 3500 (2 / 4WD 26 / 35 Gal. (USA))	V8	5.9 (360)	1996	X	MÓDULO	P74710M	CON. 4 = C / R	99	
RAM 3500 (2 / 4WD 26 / 35 Gal. SL / M.P.F.I.)	V8	5.9 (360)	1996	X	MÓDULO	P74701M	CON. 4 = C / R	98	
RAM 3500 (2 / 4WD 26 / 35 Gal. SL / T.B.I.)	V8	5.9 (360)	1996	X	MÓDULO	P74702M	CON. 4 = C / R	98	
RAM 3500 (2 / 4WD 26 / 35 Gal. SM / M.P.F.I.)	V8	5.9 (360)	1996	X	MÓDULO	P74703M	CON. 4 = C / R	98	

T Con Turbina // Con CLEANSCREEN

Gasolina

MODELO	CIL.	LTS. (PC)	AÑOS	VIN.	TIPO BOMBA	No. PARTE	OBSERVACIONES	PAG.	NOTA
--------	------	-----------	------	------	------------	-----------	---------------	------	------

Chrysler / Dodge

RAM 3500 (2 / 4WD Cabina STD.)	V8	5.9 (360)	1998-02	Y, 5, Z	MÓDULO	P74734M	CON. 4 = C / R	101	
RAM 3500 (2 / 4WD CLUB CAB 26 Gal.)	V8	5.9 (360)	1998-01	Y, 5, Z	MÓDULO	P74801M	CON. 4 = C / R	105	T
RAM 3500 (2/ 4WD CLUB CAB 34 / 35 Gal.)	V8	5.9 (360)	1998-01	Y, 5, Z	MÓDULO	P74735M	CON. 4 = C / R	101	T
RAM 3500 (2 / 4WD M tipo Carter)	V8	5.9 (360)	1995	Z	MÓDULO	P74682M	CON. 4 = C / R	96	
RAM 3500 (2 / 4WD M tipo Carter)	V8	5.9 (360)	1994	Y	MÓDULO	P74673M	CON. 5 oo C / R	96	
RAM 3500 (2 / 4WD M tipo Walbro)	V8	5.9 (360)	1995	X	MÓDULO	P74695M	CON. 4 = C / R	97	
RAM 3500	V10	8.0 (488)	1996	W	MÓDULO	P74735M		101	T
RAM 3500	V10	8.0 (488)	1996	W	KIT	P90771	No es un kit Universal	137	
RAM 4000	V8	5.9 (360)	2001-02	Z, Y	MÓDULO	P74734M	CON. 4 = C / R	101	
RAM 6500 (M.P.F.I.)	V8	5.9 (360)	1991-96	Z	MÓDULO	P74660M	CON. 5 oo C / R	95	
RAM 6500 (M.P.F.I.)	V8	5.9 (360)	1991-97	Z	KIT	P74127	No es un kit Universal	86	
RAM CHARGER (T.B.I.)	V8	5.9 (360)	1990-96	Z	MÓDULO	P74655M	CON. 5 oo S / R	95	
RAM CHARGER (T.B.I.)	V8	5.9 (360)	1990-96	Z	KIT	P74109	No es un kit Universal	85	
RAM CHARGER (M.P.F.I.)	V8	5.9 (360)	1996	Z	MÓDULO	P74705M	CON. 6 = C / R	98	
RAM RUNNER (25 o 35 Gal.)	V10	8.0 (488)	1996-97	W	MÓDULO	P74710M	CON. 4 = C / R	99	
RAM RUNNER CLUB CAB (25 Gal.)	V10	8.0 (488)	1998-01	W	MÓDULO	P74801M	CON. 4 = C / R	105	T
RAM RUNNER CLUB CAB (34 / 35 Gal.)	V10	8.0 (488)	1998-01	W	MÓDULO	P74735M	CON. 4 = C / R	101	T
RAM RUNNER CLUB CAB Cabina STD.	V10	8.0 (488)	1998-01	W	MÓDULO	P74734M	CON. 4 = C / R	101	
RAM VAN 1500 (T.B.I.)	V6	3.9 (239)	1994-96	X	MÓDULO	P74702M	CON. 6 = S / R	98	
RAM VAN 1500 (35 Gal.)	V6	3.9 (239)	1998-01	X	MÓDULO	P74735M	CON. 4 = C / R	101	T
RAM VAN 1500 (34 Gal.)	V6	3.9 (239)	1998	X	MÓDULO	P74735M	CON. 4 = C / R	101	T

T Con Turbina // Con CLEANSCREEN

Aplicaciones por marca para camionetas nacionales

Gasolina

MODELO	CIL.	LTS. (PC)	AÑOS	VIN.	TIPO BOMBA	No. PARTE	OBSERVACIONES	PAG.	NOTA
--------	------	-----------	------	------	------------	-----------	---------------	------	------

Chrysler / Dodge

RAM VAN 1500 (32 gal.)	V6	3.9 (239)	1999-00	X	MÓDULO	P74740M		101	
RAM VAN 1500 (35 gal.)	V6	3.9 (239)	1999-03	X	MÓDULO	P74800M		105	T
RAM VAN 1500	V6	3.9 (239)	1997	X	MÓDULO	P74737M	CON. 4 = C / R No aplica a Pick up	101	
RAM VAN 1500	V6	3.9 (239)	1996	X	MÓDULO	P74698M		97	
RAM VAN 1500	V6	3.9 (239)	1995	X	MÓDULO	P74658M		95	
RAM VAN 2500 (T.B.I.)	V8	5.2 (318)	1994-96	Y	MÓDULO	P74702M	CON. 6 = S / R	98	
RAM VAN 2500	V8	5.2 (318)	1996	Y	MÓDULO	P74698M		97	
RAM VAN 2500	V8	5.2 (318)	1995	Y	MÓDULO	P74658M		95	
RAM VAN 2500 (32 gal.)	V8	5.2 (318)	1999-00	V	MÓDULO	P74740M		101	
RAM VAN 2500 (35 gal.)	V8	5.2 (318)	1999-03	V	MÓDULO	P74800M		105	T
RAM VAN 2500	V8	5.9 (360)	1999-00	Z	MÓDULO	P74740M		101	
RAM VAN 3500	V8	5.9 (360)	1996-97	Z	MÓDULO	P74698M		97	
RAM VAN 3500 (32 gal.)	V8	5.9 (360)	1996-97	Z	MÓDULO	P74740M		101	
RAM VAN 3500 (35 gal.)	V8	5.9 (360)	1999-03	Z	MÓDULO	P74800M		105	T
RAM VAN 3500 (T.B.I.)	V8	5.9 (360)	1994-96	Z	MÓDULO	P74702M	CON. 6 = S / R	98	
RAM VAN 3500	V8	5.9 (360)	1995	Z	MÓDULO	P74658M		95	
TOWN & COUNTRY	V6	3.3 (201)	2005	3	KIT	P96065	Con Distancia entre ejes de 119" y Asientos plegables	138	
TOWN & COUNTRY	V6	3.3 (201)	2005	R	KIT	P96065	Con Distancia entre ejes de 119" y Asientos plegables	138	
TOWN & COUNTRY	V6	3.3 (201)	2004-05	R	MÓDULO	P76061M	Sin sistema de Asientos plegables	121	T
TOWN & COUNTRY	V6	3.3 (201)	2001-03	3	MÓDULO	P76032M		120	T
TOWN & COUNTRY	V6	3.3 (201)	2001-02	L	MÓDULO	P75026M		115	T
TOWN & COUNTRY	V6	3.3 (201)	1999-00	G	MÓDULO	P76033M		120	T
TOWN & COUNTRY	V6	3.3 (201)	2005-08	R	MÓDULO	P76065M	Con asientos plegables	122	
TOWN & COUNTRY	V6	3.3 (201)	1996-00	R	MÓDULO	P74706M		98	T
TOWN & COUNTRY	V6	3.3 (201)	1991-95	R	MÓDULO	P74656M	solo aplica para 5 pines	95	
TOWN & COUNTRY	V6	3.3 (201)	1996-00	R	MÓDULO	P74706M		98	T
TOWN & COUNTRY	V6	3.3 (201)	1991-93	R	KIT	P90606K	No es un kit Universal	136	
TOWN & COUNTRY	V6	3.3 (201)	1991-93	R	MÓDULO	P74634M	Tracción Delantera (FWD) CON CONECTOR DE 3 PINES	94	T

T Con Turbina // Con CLEANSCREEN

Gasolina

MODELO	CIL.	LTS. (PC)	AÑOS	VIN.	TIPO BOMBA	No. PARTE	OBSERVACIONES	PAG.	NOTA
--------	------	-----------	------	------	------------	-----------	---------------	------	------

Chrysler / Dodge

	TOWN & COUNTRY	V6	3.3 (201)	1994-95	L	MÓDULO	P74634M	Tracción Delantera (FWD) CON CONECTOR DE 3 PINES	94	T
N	TOWN & COUNTRY	V6	3.8 (230)	2004-07	L	MÓDULO	P76065M	Con asientos plegables	122	
N	TOWN & COUNTRY	V6	3.8 (230)	2004-07	L	MÓDULO	P76061M	Sin sistema de Asientos plegables	121	T
	TOWN & COUNTRY	V6	3.8 (230)	2005	L	KIT	P96065	Con Distancia entre ejes de 119" y Asientos plegables	138	
	TOWN & COUNTRY	V6	3.8 (230)	2001-02	L	MÓDULO	P75026M	CON. 4 = C / R	115	T
	TOWN & COUNTRY	V6	3.8 (230)	1996-00	L	MÓDULO	P74706M	CON. 3 = C / R	98	T
	TOWN & COUNTRY	V6	3.8 (230)	1996-99	R	KIT	P90606K	No es un kit Universal	136	
	TOWN & COUNTRY	V6	3.8 (230)	1994-95	L	MÓDULO	P74634M	Tracción Delantera (FWD) CON CONECTOR DE 3 PINES	94	T
	TOWN & COUNTRY	V6	3.8 (230)	1994-95	L	KIT	P90634	2WD	136	
	VOYAGER	V6	3.3 (201)	2001-03	3	MÓDULO	P76032M		120	T
	VOYAGER	V6	3.3 (201)	1998-00	G	MÓDULO	P76033M		120	T
N	VOYAGER	V6	3.3 (201)	2005-08	R	MÓDULO	P76065M	Con asientos plegables	122	
	VOYAGER	V6	3.3 (201)	1996-00	R	MÓDULO	P74706M		98	T
	VOYAGER	V6	3.3 (201)	1996-00	R	KIT	P90606K	No es un kit Universal	136	
	VOYAGER	V6	3.3 (201)	1991-95	R	MÓDULO	P74656M	solo aplica para 5 pines	95	
	VOYAGER	V6	3.3 (201)	2005-08	R	KIT	P96065	Con Distancia entre ejes de 119" y Asientos plegables	138	
	VOYAGER	V6	3.3 (201)	1991-95	3	MÓDULO	P74634M	Tracción Delantera (FWD)	94	T
	VOYAGER	V6	3.3 (201)	1991-95	3	KIT	P90634		136	
N	VOYAGER	V6	3.8 (230)	2004-05	L	MÓDULO	P76065M	Con asientos plegables	122	
	VOYAGER	V6	3.8 (230)	2004-05	L	KIT	P96065	Con asientos plegables	138	
	VOYAGER	V6	3.8 (230)	1998-99	L	MÓDULO	P74706M		98	T
	VOYAGER	V6	3.8 (230)	1998-99	L	KIT	P90606K	No es un kit Universal	136	

Ford / Lincoln

	AEROSTAR	V6	3.0 (181)	1989-97	U	ENSAMBLE	P74527S		92	
	AEROSTAR	V6	3.0 (181)	1989-97	U	KIT	P74123		86	
	AEROSTAR	V6	4.0 (244)	1990-97	X	ENSAMBLE	P74527S		92	
	AEROSTAR	V6	4.0 (244)	1990-97	X	KIT	P74123		86	
	CHASIS M450 (F53)	V8	7.5 (460)	1993-97	G	KIT	P74107		84	T
	CHASIS M450 (F53)	V8	7.5 (460)	1993-97	G	KIT	P90107		132	
N	COURIER	L4	1.6 (98)	2002-07		MÓDULO	P90150M		133	
	E-150 ECONOLINE / VAN	L6	4.9 (300)	1992-96	Y	KIT	P74107		84	T
	E-150 ECONOLINE / VAN	L6	4.9 (300)	1992-96	Y	KIT	P90107		132	
	E-150 ECONOLINE / VAN	V6	4.9 (300)	1987-91	Y	KIT	P74067		83	
	E-150 ECONOLINE / VAN	V8	5.0 (302)	1986-91	N	KIT	P74067		83	
	E-150 ECONOLINE / VAN	V8	5.8 (351)	1988-91	H	KIT	P74067		83	

T Con Turbina // Con CLEANSCREEN

Aplicaciones por marca para camionetas nacionales

Gasolina

MODELO	CIL.	LTS. (PC)	AÑOS	VIN.	TIPO BOMBA	No. PARTE	OBSERVACIONES	PAG.	NOTA
--------	------	-----------	------	------	------------	-----------	---------------	------	------

Ford / Lincoln

E-200 ECONOLINE / VAN	V6	4.9 (300)	1988-90	Y	KIT	P74067		83	
E-250 ECONOLINE / VAN	L6	4.9 (300)	1992-96	Y	KIT	P74107		84	T
E-250 ECONOLINE / VAN	L6	4.9 (300)	1992-96	Y	KIT	P90107		132	
E-350 ECONOLINE / VAN	V8	5.4 (330)	1998-99	L, Z	ENSAMBLE	P74857S	Número Anterior P75049S	108	T
E-350 ECONOLINE / VAN SUPER	V8	5.4 (330)	1998-99		ENSAMBLE	P74849H	D. 2 TURBO	108	T
ECOSPORT	L4	2.0 (122)	2004-08	1	MÓDULO	P90170		133	
ECOSPORT	L4	2.0 (122)	2004-08		KIT	P90171		133	
ESCAPE	V6	3.0 (182)	2001-04	1	MÓDULO	P74963M		112	
ESCAPE	V6	3.0 (182)	2004-07	1	MÓDULO	P76128M	MPFI Sin sistema de recuperación de vapores	123	
ESCAPE	V6	3.0 (182)	2004-07	1	MÓDULO	P76129M	MPFI Con sistema de recuperación de vapores	124	
EXCURSION TRITON	V10	6.8 (415)	2000-05	S	MÓDULO	P74998M		114	T
EXCURSION TRITON	V8	5.4 (330)	2000-05	L	KIT	P76105		123	T
EXCURSION TRITON	V10	6.8 (415)	2000-05	S	KIT	P76105	Con control de emisiones California	123	T
EXCURSION	V8	7.3 (450)	2000-03	F	KIT	P74221		92	
EXPEDITION (SOHC) TRITON	V8	4.6 (281)	2001	W	KIT	P74207		91	
EXPEDITION TRITON	V8	4.6 (281)	1997-02	W, 6	ENSAMBLE	P74876S	Número Anterior P74815S	109	T
EXPEDITION	V8	4.6 (281)	1997	W	KIT	P74176		89	
EXPEDITION	V8	4.6 (281)	1997-98	W	KIT	P74177		89	
EXPEDITION TRITON	V8	4.6 (281)	1999-02	6	ENSAMBLE	P74875S	2WD , Suspension std.	109	T
EXPEDITION TRITON	V8	4.6 (281)	1999-02	6	ENSAMBLE	P74874S	4WD	109	T
EXPEDITION TRITON	V8	4.6 (281)	1997-98	6	ENSAMBLE	P74816S	2WD , Suspension std ,servicio pesado .	106	
EXPEDITION TRITON	V8	4.6 (281)	1997	W	ENSAMBLE	P74811S	4WD	106	
EXPEDITION TRITON	V8	5.4 (330)	1999-02	L	ENSAMBLE	P74875S	2WD , Suspension std.	109	T
EXPEDITION TRITON	V8	5.4 (330)	1999-02	L	ENSAMBLE	P74874S	4WD	109	T
EXPEDITION TRITON	V8	5.4 (330)	1997-98	L	ENSAMBLE	P74816S	2WD, Suspension std, servicio pesado	106	

Gasolina

MODELO	CIL.	LTS. (PC)	AÑOS	VIN.	TIPO BOMBA	No. PARTE	OBSERVACIONES	PAG.	NOTA
--------	------	-----------	------	------	------------	-----------	---------------	------	------

Ford / Lincoln

	EXPEDITION TRITON	V8	5.4 (330)	2003-05	L	MÓDULO	P76022M		120	
N	EXPEDITION TRITON	V8	5.4 (330)	2005-08	5	MÓDULO	P76133M		124	
	EXPEDITION (SOHC) TRITON	V8	5.4 (330)	1999-01	L	KIT	P74207		91	
	EXPEDITION (DOHC) TRITON	V8	5.4 (330)	1999-00	L	KIT	P74208		91	
	EXPEDITION TRITON	V8	5.4 (330)	1997-98	L	KIT	P74177		89	
N	EXPEDITION TRITON	V8	5.4 (330)	1997-98	L	ENSAMBLE	P74811S	4WD	106	
N	EXPEDITION TRITON	V8	5.4 (330)	1997-02	L	ENSAMBLE	P74876S	Número Anterior P74815S	109	T
	EXPEDITION	V8	5.4 (330)	1997	L	KIT	P74176		89	
N	EXPLORER	V6	4.0 (244)	1999-01	E, X	ENSAMBLE	P74879S		110	T
	EXPLORER	V6	4.0 (244)	1999-01	E	KIT	P74203		90	
	EXPLORER	V6	4.0 (244)	1997-98	E, X	ENSAMBLE	P74805S		105	T
	EXPLORER	V6	4.0 (244)	1997-98	E, X	KIT	P74178		89	
	EXPLORER	V6	4.0 (244)	1995-96	X	KIT	P74159		88	T
	EXPLORER	V6	4.0 (244)	1991-94	X	ENSAMBLE	P74611S		93	
	EXPLORER	V6	4.0 (244)	1991-94	X	KIT	P74123		86	
N	EXPLORER	V8	5.0 (302)	1999-01	E, X	ENSAMBLE	P74879S		110	T
	EXPLORER	V8	5.0 (302)	1999-01	P	KIT	P74203		90	
	EXPLORER	V8	5.0 (302)	1997-98	P	ENSAMBLE	P74805S		105	T
	EXPLORER	V8	5.0 (302)	1997-98	P	KIT	P74178		89	
	EXPLORER	V8	5.0 (302)	1997	P	KIT	P74189		90	
	EXPLORER	V8	5.0 (302)	1996	P	KIT	P74159		88	T
N	EXPLORER SPORT	V6	4.0 (244)	1999-01	K	ENSAMBLE	P76156S		124	
	FREESTAR	V6	4.2 (256)	2004-05	2	MÓDULO	P76041M		121	
N	FREESTAR	V6	4.2 (256)	2004-05	2	KIT	P76230		126	T
N	FREESTAR	V6	4.2 (256)	2006-07	2	MÓDULO	P76121M	Sin arnes integrado	123	
N	F-150	V6	4.2 (256)	1998-04	2	ENSAMBLE	P74853S	Con flotador	108	T
	F-150	L6	4.9 (300)	1990-96	Y	KIT	P74107		84	T
	F-150	L6	4.9 (300)	1990-96	Y	KIT	P90107		132	
	F-150	L6	4.9 (300)	1987-89	Y	KIT	P74067		83	
N	F-150	V6	5.4 (330)	1999-01	6, W	ENSAMBLE	P74853S	Con flotador	108	T
	F-200	V6	4.9 (300)	1987-89	Y	KIT	P74067		83	
	F-250 / F-300 / F-350	V6	4.9 (300)	1987-89	Y	KIT	P74067		83	
	F-250 / F-350	V8	5.0 (302)	1990-96	N	KIT	P74107		84	T
	F-250 / F-350	V8	5.0 (302)	1990-96	N	KIT	P90107		132	
N	F-250	V8	5.4 (330)	1999-01	6, W	ENSAMBLE	P74853S	Con flotador	108	T

T Con Turbina // Con CLEANSCREEN

Aplicaciones por marca para camionetas nacionales

Gasolina

MODELO	CIL.	LTS. (PC)	AÑOS	VIN.	TIPO BOMBA	No. PARTE	OBSERVACIONES	PAG.	NOTA
--------	------	-----------	------	------	------------	-----------	---------------	------	------

Ford / Lincoln

	F-200	V6	4.9 (300)	1987-89	Y	KIT	P74067		83	
	F-250 / F-300 / F-350	V6	4.9 (300)	1987-89	Y	KIT	P74067		83	
	F-250 / F-350	V8	5.0 (302)	1990-96	N	KIT	P74107		84	T
	F-250 / F-350	V8	5.0 (302)	1990-96	N	KIT	P90107		132	
N	F-250	V8	5.4 (330)	1999-01	6, W	ENSAMBLE	P74853S	Con flotador	108	T
	F-250 (Super Duty) TRITON	V8	5.4 (330)	2005-08	5, L	KIT	P76229		126	T
	F-250 (Super Duty) TRITON	V10	6.8 (415)	2005-08	S, Y	KIT	P76229		126	T
	F-250 / F-350	V8	5.8 (351)	1990-97	H	KIT	P74107		84	T
	F-250 / F-350	V8	5.8 (351)	1990-97	H	KIT	P90107		132	
	F-350 (Super Duty) TRITON	V8	5.4 (330)	2001-03	L	MÓDULO	P74942M	Tamc. / , CHC / Exc.Calif.	111	T
	F-350 (Super Duty) TRITON	V8	5.4 (330)	2003	L	MÓDULO	P75034M	Tamc. / (Calif.) Exc.CHC (wb-137,158,172")	116	T
	F-350 (Super Duty) TRITON	V8	5.4 (330)	2003	L	MÓDULO	P75035M	Tamc. / (Calif.) Exc.CHC (wb-142, 156")	116	T
	F-350 (Super Duty) TRITON	V8	5.4 (330)	2000-04	L	MÓDULO	P75037M	Exc. Calif. (Tanque después del eje trasero)	117	
	F-350 (Super Duty) TRITON	V8	5.4 (330)	2000-04	L	KIT	P95037	Exc. Calif. (Tanque después del eje trasero)	138	
	F-350 (Super Duty) TRITON	V8	5.4 (330)	2003	L	MÓDULO	P75036M	Tamc. / (Calif.) Exc.CHC (wb-137,158,172")	116	T
	F-350 (Super Duty) TRITON	V8	5.4 (330)	2005-08	5, L	KIT	P76229		126	T
	F-350 (Super Duty) TRITON	V10	6.8 (415)	2005-08	S, Y	KIT	P76229		126	T
N	F-450 TRITON	V8	5.4 (330)	2005-06		KIT	P76230		126	T
	F-450 (Super Duty) TRITON	V10	6.8 (415)	2001-03	S	MÓDULO	P74942M	Tamc. / (Calif.) Exc.CHC	111	T
	F-450 (Super Duty) TRITON	V10	6.8 (415)	2003	S	MÓDULO	P75034M	Tamc. / (Calif.) Exc.CHC (wb-137,158,172")	116	T
	F-450 (Super Duty) TRITON	V10	6.8 (415)	2003	S	MÓDULO	P75035M	Tamc. / (Calif.) Exc.CHC (wb-142, 156")	116	T
	F-450 (Super Duty) TRITON	V10	6.8 (415)	2003	S	MÓDULO	P75036M	Tamc. / (Calif.) Exc.CHC (wb-137,158,172")	116	T
	F-450 (Super Duty) TRITON	V10	6.8 (415)	2000 04	S	MÓDULO	P75037M	Exc. Calif. (Tanque después del eje trasero)	117	
	F-450 (Super Duty) TRITON	V10	6.8 (415)	2000 04	S	KIT	P95037	Exc. Calif. (Tanque después del eje trasero)	138	
	F-450 (Super Duty) TRITON	V10	6.8 (415)	2001-03	S	MÓDULO	P74942M	Tamc. / (Calif.) Exc.CHC	111	T

T Con Turbina // Con CLEANSCREEN

Gasolina

MODELO	CIL.	LTS. (PC)	AÑOS	VIN.	TIPO BOMBA	No. PARTE	OBSERVACIONES	PAG.	NOTA
--------	------	-----------	------	------	------------	-----------	---------------	------	------

Ford / Lincoln

F-450 (Super Duty) TRITON	V10	6.8 (415)	2003	S	MÓDULO	P75034M	Tamc. / (Calif.) Exc.CHC (wb-137,158,172")	116	T
F-450 (Super Duty) TRITON	V10	6.8 (415)	2003	S	MÓDULO	P75035M	Tamc. / (Calif.) Exc.CHC (wb-142, 156")	116	T
F-450 (Super Duty) TRITON	V10	6.8 (415)	2003	S	MÓDULO	P75036M	Tamc. / (Calif.) Exc.CHC (wb-137,158,172")	116	T
F-450 (Super Duty) TRITON	V10	6.8 (415)	2005-08	S, Y	KIT	P76229		126	T
F-550 (Super Duty) TRITON	V8	5.4 (330)	2005-06		KIT	P76230		126	T
F-550 (Super Duty) TRITON	V9	6.8 (415)	2000-03		KIT	P76230		126	T
F-550 (Super Duty) TRITON	V10	6.8 (415)	2000-04	S	MÓDULO	P75037M	Exc. Calif. (Tanque después del eje trasero)	117	
F-550 (Super Duty) TRITON	V10	6.8 (415)	2000-04	S	KIT	P95037	Exc. Calif. (Tanque después del eje trasero)	138	
F-550 (Super Duty) TRITON	V10	6.8 (415)	2005-08	S, Y	KIT	P76229		126	T
F-600 / F-700 / F-800	V8	6.1 (370)	1991-93	H	KIT	P74107		84	T
F-600 / F-700 / F-800	V8	6.1 (370)	1991-93	H	KIT	P90107		132	
F-600 / F-800	V8	7.0 (429)	1991	J	KIT	P74107		84	T
F-600 / F-800	V8	7.0 (429)	1991	J	KIT	P90107		132	
F-600 / F-800	V8	7.0 (429)	1992-94	8	KIT	P74107		84	T
F-600 / F-800	V8	7.0 (429)	1992-94	8	KIT	P90107		132	
F-600 / F-800	V8	7.0 (429)	1995	J	KIT	P74107		84	T
F-600 / F-800	V8	7.0 (429)	1995	J	KIT	P90107		132	
F-700	V8	7.0 (429)	1991-97	J	KIT	P74107		84	T
F-700	V8	7.0 (429)	1991-97	J	KIT	P90107		132	
NAVIGATOR	V8	5.4 (330)	1998	L	ENSAMBLE	P74876S	Número Anterior P74815S	109	T
NAVIGATOR (DOHC)	V8	5.4 (330)	1999-02	A	KIT	P74208		91	
NAVIGATOR (SOHC)	V8	5.4 (330)	1999-01	L	KIT	P74207		91	
NAVIGATOR	V8	5.4 (330)	2005-08	5	MÓDULO	P76133M		124	
NAVIGATOR 4X4	V8	5.4 (330)	1998	L	KIT	P74177		89	
RANGER	L4	2.3 (140)	1989-97	A	KIT	P74123		86	
RANGER	L4	2.3 (140)	1985-88	A	KIT	P74028		81	
RANGER	L4	2.3 (140)	1985-88	A	KIT	P74069		83	
RANGER	L4	2.3 (140)	1989-97	A	ENSAMBLE	P74528S	CON. 4 oo S / R	92	
RANGER	L4	2.3 (140)	1990-97	A	ENSAMBLE	P74628H		93	

T Con Turbina // Con CLEANSCREEN

Aplicaciones por marca para camionetas nacionales

Gasolina

MODELO	CIL.	LTS. (PC)	AÑOS	VIN.	TIPO BOMBA	No. PARTE	OBSERVACIONES	PAG.	NOTA
--------	------	-----------	------	------	------------	-----------	---------------	------	------

Ford / Lincoln

N	RANGER	L4	2.3 (140)	2004-07	D	MÓDULO	P76122M	CON W.B. DE 112"	123	
N	RANGER	L4	2.3 (140)	2004-07	D	MÓDULO	P76131M	CON W.B. DE 126"	124	
N	RANGER	V6	2.3 (140)	2004-06	D	MÓDULO	P76123M	CON W.B. DE 118"	123	
N	RANGER	V6	2.5 (153)	2000-01	C	ENSAMBLE	P74852S	CON W.B. DE 112"	108	T
N	RANGER	V6	2.5 (153)	2000	C	ENSAMBLE	P74871S	CON W.B. DE 118"	109	
	RANGER	L4	2.5 (153)	1998-01	C	KIT	P74211		91	
	RANGER	V6	3.0 (183)	1999-00	B	KIT	P74211		91	
	RANGER	V6	3.0 (183)	1998	U	KIT	P74189		90	
	RANGER (EXC. SUPER CABINA)	V6	3.0 (181)	1991-97	U	ENSAMBLE	P74628H		93	
N	RANGER SUPER ACB	V6	3.0 (181)	2000-01	U	ENSAMBLE	P74867S	CON W.B. DE 126 "	109	T
	RANGER	V6	3.0 (181)	2002-03	U	MÓDULO	P74997M		114	
N	RANGER	V6	3.0 (182)	2004-06		MÓDULO	P76123M	CON W.B. DE 118"	123	
N	RANGER	V6	4.0 (244)	2004-06	E	MÓDULO	P76122M	CON W.B. DE 112"	123	
N	RANGER	V6	4.0 (244)	2000-01	E	ENSAMBLE	P74855S	CON W.B. DE 126"	108	T
N	RANGER SUPER ACB	V6	4.0 (244)	2000-01	E	ENSAMBLE	P74867S	CON W.B. DE 126"	109	T
N	RANGER	V6	4.0 (245)	2004-06	E	MÓDULO	P76123M	CON W.B. DE 118"	123	
N	RANGER	V6	4.0 (244)	2004-06	E	MÓDULO	P76131M	CON W.B. DE 126"	124	
	WINDSTAR	V6	3.0 (183)	1995-97	U	KIT	P74169	Número Anterior P74147	88	
	WINDSTAR	V6	3.8 (232)	1995-97	4	KIT	P74169	Número Anterior P74147	88	
N	WINDSTAR	V6	3.0 (183)	1997-98	4	ENSAMBLE	P74728H		100	
N	WINDSTAR	V6	3.0 (183)	1997-98	U	MÓDULO	P74749M		102	T
	WINDSTAR	V6	3.0 (183)	1997-98	U	KIT	P74194		90	
N	WINDSTAR	V6	3.8 (232)	1997-98	4	MÓDULO	P74749M		102	T
	WINDSTAR	V6	3.8 (232)	1997-98	4	KIT	P74194		90	
N	WINDSTAR	V6	3.0 (183)	1999-00	U	MÓDULO	P74952M		112	T
	WINDSTAR	V6	3.0 (183)	1999-00	U	KIT	P74210		91	T
N	WINDSTAR	V6	3.8 (232)	1999-00	4	MÓDULO	P74952M		112	T
	WINDSTAR	V6	3.8 (232)	1999-00	4	KIT	P74210		91	T
N	WINDSTAR	V6	3.8 (232)	2001-03	4	MÓDULO	P74961M		112	T

Honda

	CR-V (DOHC)	L4	2.4 (146)	2002-06	K24A1	KIT	P76028	PLATAFORMA JAPONESA	120	T
	ODYSSEY	V6	3.5 (214)	1999	J35A1	KIT	P72261		80	
	ODYSSEY	V6	3.5 (214)	2000-04	J35A4	KIT	P76016		119	
	PILOT	V6	3.5 (214)	2003-04	J35A4	KIT	P76016		119	
N	PILOT	V6	3.5 (214)	2005	J35A6	MÓDULO	P76306M		128	
N	PILOT	V6	3.5 (214)	2006-08	J35A9	MÓDULO	P76306M		128	
N	PILOT	V6	3.5 (214)	2006-08	J35AZ1	MÓDULO	P76306M		128	
N	ACURA MDX	V6	3.5 (214)	2005-06	J35A5	MÓDULO	P76306M		128	

T Con Turbina // Con CLEANSCREEN

Gasolina

MODELO	CIL.	LTS. (PC)	AÑOS	VIN.	TIPO BOMBA	No. PARTE	OBSERVACIONES	PAG.	NOTA
--------	------	-----------	------	------	------------	-----------	---------------	------	------

Jeep

	CHEROKEE	L6	4.0 (242)	1996	S	KIT	P72192		77	
	CHEROKEE	L6	4.0 (242)	1996	S	ENSAMBLE	P74896S		110	
	CHEROKEE	L6	4.0 (242)	1997-01	S	MÓDULO	P75040M	C / R	117	T
	CHEROKEE	L6	4.0 (244)	1997-01	S	KIT	P74186		89	
	CHEROKEE	L4	2.5 (150)	1997-00	P	MÓDULO	P75040M	C / R	117	T
	CHEROKEE	L4	2.5 (153)	1996	P	ENSAMBLE	P74896S		110	
	CHEROKEE	L4	2.5 (153)	1997-00	P	KIT	P74186		89	
	GRAND CHEROKEE	L6	4.0 (242)	2000-02	S	MÓDULO	P75041M	Número Anterior P75039M	117	T
N	GRAND CHEROKEE	L6	4.0 (242)	1997-98		MÓDULO	P75043M		117	T
	GRAND CHEROKEE	L6	4.0 (242)	1998		MÓDULO	P74708M		99	T
	GRAND CHEROKEE	L6	4.0 (242)	1993-94		MÓDULO	P74663M		96	T
N	GRAND CHEROKEE	V6	3.7 (223)	2005	K	MÓDULO	P76067M		122	
	GRAND CHEROKEE	V6	3.7 (230)	2005	K	KIT	P96067	No es un kit Universal	138	
	GRAND CHEROKEE	V8	4.7 (285)	2000-02	N	MÓDULO	P75041M	Número Anterior P75039M	117	T
N	GRAND CHEROKEE	V8	4.7 (287)	2005	N	MÓDULO	P76067M		122	
	GRAND CHEROKEE	V8	4.7 (287)	2005	N	KIT	P96067	No es un kit Universal	138	
N	GRAND CHEROKEE	V8	5.2 (318)	1997-98	Y	MÓDULO	P75043M		117	T
	GRAND CHEROKEE	V8	5.2 (318)	1995	Y	MÓDULO	P74697M		97	T
	GRAND CHEROKEE	V8	5.2 (318)	1996	Y	MÓDULO	P74708M		99	T
	GRAND CHEROKEE	V8	5.2 (318)	1993-94		MÓDULO	P74663M		96	T
N	GRAND CHEROKEE (Motor HEMI)	V8	5.7 (345)	2005	N , 2	MÓDULO	P76067M		122	
	GRAND CHEROKEE (Motor HEMI)	V8	5.7 (345)	2005	2	KIT	P96067	No es un kit Universal	138	
N	GRAND CHEROKEE	V8	5.9 (360)	1997-98		MÓDULO	P75043M		117	T
N	LIBERTY	V6	3.7 (230)	2005-07	K	KIT	P76211		125	T
	WRANGLER	L4	2.4 (148)	2005-06	1	KIT	P90677		137	
N	WRANGLER	L4	2.5 (153)	1997-02	P	MÓDULO	P75046M	TQE . de 15 galones	117	T
	WRANGLER	L4	2.5 (153)	1997-02	P	MÓDULO	P75045M	TQE. de 19 galones	117	T
N	WRANGLER	L6	4.0 (244)	1999	S	MÓDULO	P75046M	TQE . de 15 galones	117	T
	WRANGLER	L6	4.0 (244)	1997-98	S	KIT	P74186		89	
	WRANGLER	L6	4.0 (244)	1997-02	S	MÓDULO	P75045M	TQE. de 19 galones	117	T
	WRANGLER	L6	4.0 (244)	1997-02	S	KIT	P74186		89	

Mitsubishi

	MONTERO	V6	3.5 (215)	1997-99	6G74	KIT	P72242		79	
--	---------	----	-----------	---------	------	-----	--------	--	----	--

T Con Turbina // Con CLEANSCREEN

Aplicaciones por marca para camionetas nacionales

Gasolina

MODELO	CIL.	LTS. (PC)	AÑOS	VIN.	TIPO BOMBA	No. PARTE	OBSERVACIONES	PAG.	NOTA
--------	------	-----------	------	------	------------	-----------	---------------	------	------

Nissan

N	ARMADA	V8	5.6 (341)	2005-08	VK56DE	MÓDULO	P76360M		130	
	FRONTIER	L4	2.4 (146)	1998-99	KA24DE	KIT	P72192D		78	
	FRONTIER	L4	2.4 (146)	1999-04	KA24DE	KIT	P76039		121	
N	FRONTIER	L4	2.4 (146)	2001-04	KA24DE	KIT	P76214	Con sistema de aviso de combustible bajo	125	
	FRONTIER	V6	3.3 (201)	1999-04	VG33DE	KIT	P76039		121	
N	MURANO	V6	3.5 (215)	2003-07	VQ35DE	MÓDULO	P76359M		129	
	PATHFINDER	V6	3.3 (201)	1997-98	VG33E	KIT	P72192B		78	
	PATHFINDER	V6	3.3 (201)	1999	VG33DE	KIT	P72192B		78	
	PATHFINDER	V6	3.5 (215)	2001-04	VQ35DE	KIT	P76036		121	
N	PATHFINDER ARMADA	V8	5.6 (341)	2004	VK56DE	MÓDULO	P76360M		130	
	PICK UP	L4	2.4 (146)	1992-93	KA24E	KIT	P72128		76	
	PICK UP	L4	2.4 (146)	1995	KA24E	KIT	P72128A		76	
	PICK UP	L4	2.4 (146)	1995-97	KA24E	KIT	P72192D		78	
	PICK UP 4X2	V6	3.0 (181)	1993	VG30E	KIT	P72195		78	
N	PICK UP 4X2 KING CAB	L4	2.4 (146)	1988-89	Z24I	KIT	P92068	Sustituye a la P72068	137	
N	PICK UP 4X4 KING CAB	L4	2.4 (146)	1992-94	KA24E	KIT	P92068	Sustituye a la P72068	137	
	PICK UP 4X4 KING CAB	V6	3.0 (181)	1993	VG30E	KIT	P72195		78	
	QUEST	V6	3.0 (181)	1993-98	VG30E	KIT	P74144		87	
	QUEST	V6	3.3 (200)	1999-02	VG33DE	KIT	P74212		91	
	INFINITI QX4	V6	3.5 (215)	2001-03	VQ35DE	KIT	P76036		121	
N	INFINITI QX56	V8	5.6 (341)	2004-06	VK56DE	MÓDULO	P76360M		130	
N	TITAN	V8	5.6 (341)	2004-07	VK56DE	MÓDULO	P76360M		130	
N	URVAN	L4	2.4 (142)	2000-07	KA24DE	KIT	P90212		134	
	X-TERRA	L4	2.4 (146)	2000-04	KA24DE	KIT	P76039		121	
	X-TERRA	V6	3.3 (201)	2001-04	VG33DE	KIT	P76039		121	

Toyota

RAV4	V6	2.4 (144)	2004	2AZFE	KIT	P76004		118	
SOLARA	V6	3.3 (200)	2004	3MZFE	KIT	P76004		118	

Bombas Electricas Universales (En Linea) 12 Volts

Hi Performace	L4, V6, V8		Todos		KIT	P4594	Gasolina c/sin plomo, diesel	72	
Todos con carburador	L4, V6, V8		Todos		KIT	P60108	Electrónica	73	
Todos con carburador	L4, V6, V8		Todos		KIT	P60430	Filtro Doble	73	

T Con Turbina // Con CLEANSCREEN

Gasolina

MODELO	CIL.	LTS. (PC)	AÑOS	VIN.	TIPO BOMBA	No. PARTE	OBSERVACIONES	PAG.	NOTA
--------	------	-----------	------	------	------------	-----------	---------------	------	------

Bombas Electricas Universales (En Línea) 12 Volts

Todos con carburador	L4, V6, V8		Todos		KIT	P74019	Cilíndrica	80	
Todos con carburador	L4, V6, V8		Todos		KIT	P74020	Cilíndrica	81	
Todos con carburador	L4, V6, V8		Todos		KIT	P74029	Cilíndrica	81	
Todos con carburador	V6, V8		Todos		KIT	P60432	Tipo Facet Alta Presión	74	
Todos con carburador	L4, V6		Todos		KIT	P60433	Tipo Facet Baja Presión	74	

NOTA : Las Bombas Universales sólo aplican a vehículos con carburador, con bombas en línea. No se usan dentro del tanque de gasolina. Estas bombas son para gasolina y no para líquidos como el Diesel o petróleo

Aplicaciones por marca para vehículos importados

Gasolina

MODELO	CIL.	LTS. (PC)	AÑOS	VIN.	TIPO BOMBA	No. PARTE	OBSERVACIONES	PAG.	NOTA
--------	------	-----------	------	------	------------	-----------	---------------	------	------

Acura

INTEGRA	L4	1.6 (97)	1986-89	D16A1	KIT	P70199		75	
INTEGRA	L4	1.8 (112)	1990-93	B18A1	KIT	P72090		76	
INTEGRA	L4	1.7 (105)	1992-93	B17A1	KIT	P72165		77	
INTEGRA	L4	1.8 (112)	1992	B18A1	KIT	P72165		77	
LEGEND	V6	3.2 (198)	1991-95	C32A1	KIT	P72090		76	
LEGEND	V6	2.5 (151)	1986-87	C25A1	KIT	P72165		77	
LEGEND	V6	2.7 (165)	1987-90	C27A1	KIT	P72165		77	
LEGEND	V6	3.2 (198)	1994-95	C32A1	KIT	P72165		77	
NSX	V6	3.0 (181)	1991-96	C30A1	KIT	P72165		77	
VIGOR	V6	2.5 (151)	1992-94	G25A1	KIT	P72090		76	

Audi

100	L4	1.9 (118)	1977	YC	KIT	P60424		73	
5000	L4	2.0 (121)	1979	CN	KIT	P60424		73	
5000	L4	2.1 (128)	1978		KIT	P60424		73	
5000	L4	2.1 (128)	1985		KIT	P72140			
5000S QUATTRO	L4	2.2 (135)	1985-87	MC	KIT	P72140			
FOX	L4	1.6 (97)	1977-79	YG, YH, YK	KIT	P60424		73	
QUATTRO	L4	2.2 (135)	1985	WX	KIT	P72140			
TURBO	L4	2.2 (135)	1987		KIT	P72140			

BMW

320i	L4	1.8 (112)	1980-83	M10	KIT	P60424		73	
320i	L4	2.0 (121)	1979	M10	KIT	P60424		73	

Buick

Century	V6	2.5 (151)	1982-84	R	KIT	P60292		73	
Century	V6	2.5 (151)	1983	R	KIT	P60293		73	
Century	V6	3.0 (181)	1982-83	E	KIT	P60293		73	
Century	V6	2.5 (151)	1985-86	R	KIT	P60459		74	
Century	V6	2.8 (173)	1986-87		KIT	P60460		74	
Century	V6	3.8 (231)	1984-87	3	KIT	P60460		74	
Century	V6	3.0 (181)	1984-85	E	KIT	P60461		74	
Century	V6	2.5 (151)	1982-85	R	KIT	P60567		75	
Century	V6	2.5 (151)	1985-86	R	KIT	P60852		75	
Century	V6	2.8 (173)	1987-88	W	KIT	P74045		82	
Century	V6	3.3 (204)	1989-92	N	KIT	P74045		82	
Century	V6	3.8 (231)	1987-88	3	KIT	P74045		82	
Electra	V6	3.8 (231)	1985	3	KIT	P60460		74	
Electra	V6	3.8 (231)	1987-88	3 / 1987, C / 1988	KIT	P60460		74	

T Con Turbina // Con CLEANSCREEN

Gasolina

MODELO	CIL.	LTS. (PC)	AÑOS	VIN.	TIPO BOMBA	No. PARTE	OBSERVACIONES	PAG.	NOTA
--------	------	-----------	------	------	------------	-----------	---------------	------	------

Buick

Electra	V6	3.0 (181)	1985	E	KIT	P60461		74	
Electra	V6	3.8 (231)	1988-90	C	KIT	P74045		82	
Estate Wagon	V8	5.0 (302)	1991		KIT	P74070		83	
Hearse / Limo	V8	5.7 (350)	1996		KIT	P74074		83	
LeSabre	V6	3.8 (231)	1987-88	3	KIT	P60460		74	
LeSabre	V6	3.8 (231)	1988-92	C	KIT	P74045		82	
Park Avenue	V6	3.8 (231)	1985		KIT	P60460		74	
Park Avenue	V6	3.8 (231)	1988-95	L	KIT	P74045		82	
Roadmaster	V8	5.7 (350)	1992-93	7	KIT	P74070		83	
Roadmaster	V8	5.7 (350)	1996	P	KIT	P74074		83	
Skyhawk	L4	1.8 (112)	1982-84	O	KIT	P60292		73	
Skyhawk	L4	2.0 (121)	1983-84	B	KIT	P60293		73	
Skyhawk	L4	1.8 (112)	1982-84	O	KIT	P60567		75	
Skyhawk	L4	2.0 (121)	1983-84	P	KIT	P60567		75	
Skyhawk	L4	1.8 (112)	1985-86	O	KIT	P60852		75	
Skyhawk	L4	2.0 (121)	1985-86	P	KIT	P60852		75	
Skyhawk	V6	2.5 (151)	1985-86		KIT	P60852		75	
Skylark	V6	2.5 (151)	1982-84	R	KIT	P60292		73	
Skylark	V6	2.5 (151)	1982	R	KIT	P60293		73	
Skylark	V6	2.5 (151)	1982-85	R	KIT	P60567		75	
Somerset Regal	V6	2.5 (151)	1985-86	U	KIT	P60852		75	

Cadillac

Cimarron	L4	2.0 (121)	1983-84		KIT	P60293		73	
Cimarron	L4	2.0 (121)	1983-84	P	KIT	P60567		75	
Cimarron	L4	2.0 (121)	1985-86	P	KIT	P60852		75	
DeVille	V6	4.1 (250)	1985-86	8	KIT	P60459		74	
DeVille	V6	4.1 (250)	1982-85	8	KIT	P60567		75	
DeVille	V8	6.0 (368)	1981	9	KIT	P60567		75	
DeVille	V6	4.1 (250)	1985-86	8	KIT	P60852		75	
DeVille	V8	4.5 (273)	1990	3	KIT	P74045		82	
N DeVille	V8	4.6 (281)	1994-98	9, Y	MÓDULO	P74747M	32 valv. Sin evaporador	102	T
DeVille	V8	4.9 (298)	1991-93	B	KIT	P74045		82	
El dorado	V8	5.7 (350)	1979-80	B / 1979, 8 / 1980	KIT	P60293		73	
El dorado	V6	4.1 (250)	1982-85	8	KIT	P60567		75	
N El dorado	V8	4.6 (281)	1994-98	9, Y	MÓDULO	P74747M	32 valv. Sin evaporador	102	T
El dorado	V8	6.0 (368)	1980-81	9	KIT	P60567		75	
Fleetwood-Brougham	V6	4.1 (250)	1985-86	8	KIT	P60459		74	
Fleetwood-Brougham	V6	4.1 (250)	1985-86		KIT	P60470		74	
Fleetwood-Brougham	V6	4.1 (250)	1982-85	8	KIT	P60567		75	
Fleetwood-Brougham	V8	6.0 (368)	1981-84	9	KIT	P60567		75	
Fleetwood-Brougham	V6	4.1 (250)	1985-86	8	KIT	P60852		75	
Fleetwood-Brougham	V8	4.5 (273)	1990	3	KIT	P74045		82	

Aplicaciones por marca para vehículos importados

Gasolina

MODELO	CIL.	LTS. (PC)	AÑOS	VIN.	TIPO BOMBA	No. PARTE	OBSERVACIONES	PAG.	NOTA
--------	------	-----------	------	------	------------	-----------	---------------	------	------

Cadillac

Fleetwood-Brougham	V8	4.9 (298)	1991-93		KIT	P74045		82	
Fleetwood-Brougham	V8	5.7 (350)	1993	7	KIT	P74070		83	
Fleetwood-Brougham	V8	5.7 (350)	1994	P	KIT	P74074		83	
Fleetwood-Brougham	V8	5.7 (350)	1996	P	KIT	P74074		83	
Limo	V6	4.1 (250)	1985		KIT	P60567		75	
Limo	V8	6.0 (368)	1980-84		KIT	P60567		75	
Limo	V8	4.9 (298)	1991		KIT	P74045		82	
Limo	V8	5.0 (307)	1990		KIT	P74045		82	
Seville	V8	5.7 (350)	1980	8	KIT	P60293		73	
Seville	V6	4.1 (250)	1982-85	8	KIT	P60567		75	
Seville	V8	4.6 (281)	1994-98	9, Y	MÓDULO	P74747M	32 valv. Sin evaporador	102	T
Seville	V8	6.0 (368)	1980-81	9	KIT	P60567		75	

Chevrolet

Beretta	L4	2.0 (121)	1987-89	1	KIT	P74051		82	
Blazer	V8	5.7 (350)	1987-94	H / 1987, K / 1988-89	KIT	P74000		80	
Blazer	V8	5.7 (350)	1987-94	K / 1990-91, K / 1994	KIT	P74000		80	
Bravada	V6	4.3 (262)	1991-94		KIT	P74002		80	
Camaro	V6	2.5 (151)	1982-83	F	KIT	P60293		73	
Camaro	V8	5.0 (305)	1984	G	KIT	P60293		73	
Camaro	V6	2.5 (151)	1982-84	2	KIT	P60567		75	
Camaro	V8	5.0 (305)	1982-83	7 / 1982, S / 1983	KIT	P60567		75	
Camaro	V8	5.7 (350)	1993-96	P	KIT	P74131		87	
Camaro	V6	2.5 (151)	1985-86	2	KIT	P60852		75	
Caprice	V6	4.3 (262)	1985-86	Z	KIT	P60470		74	
Caprice	V6	4.3 (262)	1990	Z	KIT	P60567		75	
Caprice	V6	4.3 (262)	1985-86	Z	KIT	P60852		75	
Caprice	V6	4.3 (262)	1987-89	Z	KIT	P74002		80	
Caprice	V6	4.3 (262)	1992-93	Z	KIT	P74070		83	
Caprice	V8	5.0 (305)	1991-93	E	KIT	P74070		83	
Caprice	V8	5.7 (350)	1991-93	7	KIT	P74070		83	
Caprice	V6	4.3 (265)	1996	W	KIT	P74074		83	
Caprice	V8	5.7 (350)	1996	P	KIT	P74074		83	
Cavalier	L4	2.0 (121)	1983-84	B	KIT	P60293		73	
Cavalier	L4	2.0 (121)	1983-84	P	KIT	P60567		75	
Cavalier	L4	2.0 (121)	1985-86	P	KIT	P60852		75	
Cavalier	L4	2.0 (121)	1987-89	1	KIT	P74051		82	
Celebrity	V6	2.5 (151)	1983-84	R	KIT	P60292		73	

T Con Turbina // Con CLEANSCREEN

Gasolina

MODELO	CIL.	LTS. (PC)	AÑOS	VIN.	TIPO BOMBA	No. PARTE	OBSERVACIONES	PAG.	NOTA
--------	------	-----------	------	------	------------	-----------	---------------	------	------

Chevrolet

Celebrity	V6	2.5 (151)	1982	R	KIT	P60293		73	
Celebrity	V6	2.5 (151)	1986	R	KIT	P60459		74	
Celebrity	V6	2.8 (173)	1985-86	W	KIT	P60460		74	
Celebrity	V6	2.5 (151)	1982-85	R	KIT	P60567		75	
Celebrity	V6	2.5 (151)	1987-88	R	KIT	P74002		80	
Celebrity	V6	2.8 (173)	1987	W	KIT	P74045		82	
Celebrity	V6	2.8 (173)	1988-89	W	KIT	P74045		82	
Celebrity	V6	3.1 (189)	1990	T	KIT	P74045		82	
Celebrity	V6	2.5 (151)	1988-90	R	KIT	P74051		82	
Chevette	L4	1.8 (112)	1983-84	D	KIT	P60567		75	
Citation	V6	2.5 (151)	1983-84	R	KIT	P60292		73	
Citation	V6	2.5 (151)	1982	R	KIT	P60293		73	
Citation	V6	2.8 (173)	1985	W	KIT	P60460		74	
Citation	V6	2.5 (151)	1982-85	R	KIT	P60567		75	
Corsica	L4	2.0 (121)	1987-89	1	KIT	P74051		82	
Corvette	V8	5.7 (350)	1982-84	8	KIT	P60567		75	
Corvette	V8	5.7 (350)	1992-95	P	KIT	P74074		83	
Cutlass Calais	V6	2.5 (151)	1987		KIT	P74002		80	
Cutlass Calais	V6	2.5 (151)	1988-91	U	KIT	P74051		82	
Cutlass Ciera	V6	2.5 (151)	1987-88	R	KIT	P74002		80	
Cutlass Ciera	V6	2.5 (151)	1988-92	R	KIT	P74051		82	
Impala	V6	4.3 (262)	1985	Z	KIT	P60470		74	
Impala	V6	4.3 (262)	1985	Z	KIT	P60852		75	
Impala SS	V8	5.7 (350)	1994	P	KIT	P74074		83	
Impala SS	V8	5.7 (350)	1996	P	KIT	P74074		83	
Monte Carlo	V6	4.3 (262)	1986	Z	KIT	P60567		75	
Monte Carlo	V6	4.3 (262)	1985	Z	KIT	P60852		75	
Monte Carlo	V6	4.3 (262)	1987-88	Z	KIT	P74002		80	
Monte Carlo	V6	3.4 (207)	2000-03	E	MODULO	P74928M		111	T
Monte Carlo	V6	3.8 (231)	2000-03	K	MODULO	P74928M		111	T
Nova	L4	1.6 (97)	1988	5	KIT	P72165		77	
Pontiac Fiero	V6	2.5 (151)	1985-88	R	KIT	P74002		80	
Pontiac Parisienne	V6	4.3 (262)	1986	Z	KIT	P74002		80	
Pontiac Trans Sport	V6	3.1 (189)	1990-95		KIT	P74002		80	
Regal	V6	3.8 (231)	1998-99	K	MÓDULO	P74792M		104	T
Spectrum	L4	1.5 (92)	1987-88	9	KIT	P72165		77	
Sprint	L4	1.0 (61)	1987-88	2	KIT	P72090		76	

T Con Turbina // Con CLEANSCREEN

Aplicaciones por marca para vehículos importados

Gasolina

MODELO	CIL.	LTS. (PC)	AÑOS	VIN.	TIPO BOMBA	No. PARTE	OBSERVACIONES	PAG.	NOTA
--------	------	-----------	------	------	------------	-----------	---------------	------	------

Chrysler

"E" Class	L4	2.2 (135)	1984	E	KIT	P74115		85	
Conquest	V6	2.6 (156)	1987-89	N, H / 1987, N / 1988-89	KIT	P70199		75	
Daytona (Canadian)	L4	2.2 (135)	1985-88	E	KIT	P74115		85	
Laser	L4	2.2 (135)	1986	E	KIT	P74115		85	
Laser	L4	2.2 (135)	1985	D, E	KIT	P74116		85	
LeBaron	L4	2.2 (135)	1984-88	E	KIT	P74115		85	
LeBaron	L4	2.2 (135)	1985	D	KIT	P74116		85	
New Yorker	L4	2.2 (135)	1986-88	E	KIT	P74115		85	
Cirrus	V6	2.5 (153)	1998-00	H	MÓDULO	P74802M		105	T
Cirrus	V6	2.5 (153)	1995-97	H	MÓDULO	P74693M		97	T
Concorde	V6	3.5 (215)	1993-95	F	MÓDULO	P74662M		95	T
Concorde	V6	2.7 (165)	1998-99	R	MÓDULO	P74819M		106	T
Concorde	V6	3.2 (198)	1998-99	J	MÓDULO	P74819M		106	T
Concorde	V6	3.3 (201)	1993-95	T	MÓDULO	P74662M		95	T
Concorde	V6	3.3 (201)	1996	T	MÓDULO	P74707M		98	T

Daihatsu

Charade	L4	1.0 (61)	1992		KIT	P72090		76	
Charade	L4	1.3 (79)	1992		KIT	P72090		76	
Rocky	L4	1.6 (97)	1989-92		KIT	P70199		75	

Delorean

320i		1.8 (112)	1980-83	M10	KIT	P60424		73	
------	--	-----------	---------	-----	-----	--------	--	----	--

Dodge

2000 GTX (Canadian)	L4	1.5 (92)	1990		KIT	P72090		76	
600	L4	2.2 (135)	1986-88	E	KIT	P74115		85	
600	L4	2.2 (135)	1985	D	KIT	P74116		85	
Aries	L4	2.2 (135)	1986-88		KIT	P74115		85	
Charger	L4	2.2 (135)	1985-88		KIT	P74115		85	
Colt	L4	1.6 (97)	1984	F	KIT	P70199		75	
Colt	L4	1.5 (92)	1989-90	X / 1989, X, K / 1990	KIT	P72165		77	
Colt	L4	1.6 (97)	1989	F	KIT	P72165		77	
Colt	L4	1.6 (97)	1985-89	F / 1985- 88, F, Y / 1989	KIT	P72165		77	
Colt	L4	1.8 (112)	1989-90	T	KIT	P72165		77	

T Con Turbina // Con CLEANSCREEN

Aplicaciones por marca para vehículos importados

Gasolina

MODELO	CIL.	LTS. (PC)	AÑOS	VIN.	TIPO BOMBA	No. PARTE	OBSERVACIONES	PAG.	NOTA
--------	------	-----------	------	------	------------	-----------	---------------	------	------

Dodge

Colt	L4	2.0 (121)	1991	V	KIT	P72165		77	
Conquest	V6	2.6 (156)	1984-86	H / 1984-85, H, N / 1986	KIT	P70199		75	
Daytona	L4	2.2 (135)	1985-88	E	KIT	P74115		85	
Daytona	L4	2.2 (135)	1985	D	KIT	P74116		85	
Lancer	L4	2.2 (135)	1986-88	E	KIT	P74115		85	
Lancer	L4	2.2 (135)	1985	D	KIT	P74116		85	
Shadow	L4	2.2 (135)	1987-88	E	KIT	P74115		85	
Stealth	V6	3.0 (181)	1991-95	C / 1991- 92, K / 1993-95	KIT	P72165		77	
Vista	L4	2.0 (121)	1987		KIT	P70199		75	
Vista	L4	2.0 (121)	1988-91	V	KIT	P72165		77	

Ford

Capri	L4	2.3 (140)	1983	W	KIT	P74096		84	
Capri	V6	3.8 (232)	1984-85	3	KIT	P74096		84	
Capri	V8	5.0 (302)	1984	F	KIT	P74096		84	
Cougar	V8	5.0 (302)	1983	F	KIT	P74096		84	
Cougar	V8	5.0 (302)	1983-84	F	KIT	P74028		81	
Cougar Turbo	L4	2.3 (140)	1984	W	KIT	P74067		83	
Cougar H.O.	V8	5.0 (302)	1988-89		ENSAMBLE	P74643S		94	
Thunderbird H.O.	V8	5.0 (302)	1988-89		ENSAMBLE	P74643S		94	
Crown Victoria	V8	4.6 (281)	1995-96	W	KIT	P74139		87	
Crown Victoria	V8	4.6 (281)	1993-94	W	KIT	P74153		88	
Festiva	L4	1.3 (79)	1989-93	H	KIT	P72165		77	
Freestar	V6	4.2 (256)	2004-07	2	MÓDULO	P76121M	Sin arnes integrado	123	
Continental	V8	5.0 (302)	1983-84	F	KIT	P74096		84	
Lincoln Mark VII	V8	5.0 (302)	1984	F	KIT	P74096		84	
LTD	V6	3.8 (232)	1984-86	3	KIT	P74067		83	
Marquis	V6	3.8 (232)	1984-86	3	KIT	P74067		83	
Marquis	V6	3.8 (232)	1984	3	KIT	P74096		84	
Mercury Sable	V6	2.5 (153)	1986	D	KIT	P74095		84	
Mustang	V8	5.0 (302)	1994	T, D	KIT	P74117		86	
Mustang	L4	2.3 (140)	1991-93	M	KIT	P74119		86	
Mustang	V6	3.8 (232)	1994-97	4	KIT	P74119		86	
Mustang	V8	4.6 (281)	1996-97	X	KIT	P74119		86	
Mustang	V8	5.0 (302)	1991-95	E / 1991- 93, D / 1994-95	KIT	P74119		86	

T Con Turbina // Con CLEANSCREEN

Aplicaciones por marca para vehículos importados

Gasolina

MODELO	CIL.	LTS. (PC)	AÑOS	VIN.	TIPO BOMBA	No. PARTE	OBSERVACIONES	PAG.	NOTA
--------	------	-----------	------	------	------------	-----------	---------------	------	------

Ford

Mustang	L4	2.3 (140)	1983-86	W / 1983-84, T / 1985-86	KIT	P74028		81	
Mustang	V6	3.8 (232)	1984-85	3	KIT	P74028		81	
Probe		2.2 (135)	1989-92	C	KIT	P72165		77	
Taurus	V6	2.5 (153)	1986-88	D	KIT	P74064		82	
Taurus	V6	3.0 (183)	1989-95	Y	KIT	P74117		86	
Taurus	V6	3.2 (195)	1993-95	P	KIT	P74117		86	
Taurus	V6	3.8 (232)	1994-95	4	KIT	P74117		86	
Tempo	L4	2.3 (140)	1987	S	KIT	P74064		82	
Tempo	L4	2.3 (140)	1988-89	X	KIT	P74092		84	
Tempo	L4	2.3 (140)	1992	X	KIT	P74145		88	
Tempo	L4	2.3 (140)	1994	X	KIT	P74145		88	
Tempo	V6	3.0 (183)	1992	U	KIT	P74145		88	
Tempo	V6	3.0 (183)	1994	U	KIT	P74145		88	
Thunderbird	L4	2.3 (140)	1983-84	W	KIT	P74028		81	
Thunderbird	L4	2.3 (140)	1985-88	W / 1985-87, T / 1988	KIT	P74103		84	
Thunderbird	L4	2.3 (140)	1984	W	KIT	P74067		83	
Thunderbird	V6	3.8 (232)	1989-93	R, 4	KIT	P74118		86	
Thunderbird	V6	3.8 (232)	1985-88	3 / 1985-87, 4 / 1988	KIT	P74103		84	
Thunderbird	V6	3.8 (232)	1984	3	KIT	P74028		81	
Thunderbird	V6	3.8 (232)	1984	3	KIT	P74067		83	
Thunderbird	V8	5.0 (302)	1991-93	T	KIT	P74118		86	
Thunderbird	V8	5.0 (302)	1985-88	F	KIT	P74103		84	

Geo

Prizm	L4	1.6 (97)	1989-92	6, 5	KIT	P72165		77	
Spectrum	L4	1.5 (92)	1989	9	KIT	P72165		77	
Safari	V6	2.5 (151)	1985-86	E	KIT	P60852		75	
Safari	V6	4.3 (262)	1986	Z	KIT	P60852		75	
Safari	V6	4.3 (262)	1992-95	W	KIT	P74074		83	
Syclone	V6	4.3 (262)	1991		KIT	P74074		83	

Honda

Accord	L4	2.0 (122)	1986-89	A20A1	ENSAMBLE	P77008H		130	
Accord	L4	2.0 (122)	1986	BS	ENSAMBLE	P77008H		130	
Accord	L4	1.8 (112)	1985	ES2	KIT	P70199		75	

T Con Turbina // Con CLEANSCREEN

Gasolina

MODELO	CIL.	LTS. (PC)	AÑOS	VIN.	TIPO BOMBA	No. PARTE	OBSERVACIONES	PAG.	NOTA
--------	------	-----------	------	------	------------	-----------	---------------	------	------

Honda

Accord	L4	2.0 (121)	1986-89	BS / 1986, A20A3 / 1987-89	KIT	P72090		76	
Accord	L4	2.2 (135)	1990-91	F22A1, F22A4, F22A6	KIT	P72090		76	
Accord	L4	2.0 (121)	1986-89	BS / 1986, A20A1 / 1987-89	KIT	P72190		77	
Civic	L4	1.5 (92)	1987		KIT	P70199		75	
Civic	L4	1.5 (92)	1988-91		KIT	P72165		77	
Civic	L4	1.6 (97)	1988-91		KIT	P72165		77	
Integra	L4	1.8 (112)	1994-99	B18B1	KIT	P72241		79	
Integra	L4	1.8 (112)	1994-01	B18C1	KIT	P72241		79	
Integra	L4	1.8 (112)	1994-99	B18C5	KIT	P72241		79	
Prelude	L4	2.0 (121)	1985-87		KIT	P70199		75	
Prelude	L4	2.2 (135)	1992-93	F22A1	KIT	P72090		76	
Prelude	L4	2.3 (140)	1992-93	A23A1	KIT	P72090		76	
Prelude	L4	2.0 (121)	1988-91	B20A5	KIT	P72165		77	
Prelude	L4	2.1 (128)	1990-91	B21A1	KIT	P72165		77	
Prelude	L4	2.2 (135)	1994-96	F22A1	KIT	P72165		77	
Prelude	L4	2.2 (135)	1994-96	H22A1	KIT	P72165		77	
Prelude	L4	2.2 (135)	1993-94	H22A1	KIT	P72165		77	
Prelude	L4	2.2 (135)	1993-94	F22A1	KIT	P72165		77	
Prelude	L4	2.3 (140)	1994-95	H23A1	KIT	P72165		77	
Prelude	L4	2.0 (121)	1988-89		KIT	P72190		77	

Hyundai

Excel	L4	1.5 (92)	1990-94		KIT	P72187		77	
Scoupe	L4	1.5 (92)	1991-95		KIT	P72187		77	

Infiniti

G20	L4	2.0 (121)	1991-94	SR20DE	KIT	P72193		78	
-----	----	-----------	---------	--------	-----	--------	--	----	--

Isuzu

I-Mark	L4	1.5 (92)	1987-89		KIT	P72165		77	
Rodeo	V6	2.6 (156)	1991-93		KIT	P72193		78	
Rodeo	V6	3.2 (195)	1994-95		KIT	P72193		78	
Trooper	V6	3.2 (195)	1992-93		KIT	P72193		78	

T Con Turbina // Con CLEANSCREEN

Aplicaciones por marca para vehículos importados

Gasolina

MODELO	CIL.	LTS. (PC)	AÑOS	VIN.	TIPO BOMBA	No. PARTE	OBSERVACIONES	PAG.	NOTA
--------	------	-----------	------	------	------------	-----------	---------------	------	------

Jeep

Alliance	L4	1.4 (86)	1983-87		KIT	P74032		81	
Alliance	L4	1.7 (105)	1985-87		KIT	P74032		81	
Alliance	L4	2.0 (121)	1987		KIT	P74032		81	
Briarwood	L4	2.4 (146)	1991		KIT	P74057		82	
Briarwood	V6	4.0 (243)	1991		KIT	P74057		82	
Briarwood	V6	4.0 (243)	1993		KIT	P74057		82	
Encore	L4	1.4 (86)	1984-85		KIT	P74032		81	
Encore	L4	1.7 (105)	1985-86		KIT	P74032		81	
Summit	L4	1.5 (92)	1990	X	KIT	P72090		76	
Summit	L4	1.6 (97)	1990	Y	KIT	P72090		76	
Summit	L4	1.5 (92)	1989	X	KIT	P72165		77	
Talon	L4	1.8 (112)	1993	B	KIT	P72090		76	
Talon	L4	2.0 (121)	1993-94	F	KIT	P72090		76	
Vista	L4	1.6 (97)	1989		KIT	P72165		77	
Vista (Canadian)	L4	2.0 (121)	1989-90	V	KIT	P72165		77	

Lexus

ES250	V6	2.5 (151)	1991	2VZFE	KIT	P72165		77	
LS400	V6	4.0 (243)	1991-98	1UZFE	KIT	P72165		77	

Lincoln

Continental	V8	5.0 (302)	1985-87	F	KIT	P74103		84	
Continental	V6	3.8 (232)	1988-94	4	KIT	P74117		86	
Mark Series	V8	5.0 (302)	1985-87	F / 1985, M,F / 1986-87	KIT	P74103		84	
Town Car	V8	4.6 (281)	1995-96	W	KIT	P74139		87	
Town Car	V8	4.6 (281)	1993-94	W	KIT	P74153		88	

Mazda

323	L4	1.6 (97)	1986-92		KIT	P72165		77	
626	L4	2.0 (121)	1986-87		KIT	P72165		77	
626		2.2 (135)	1988-92		KIT	P72165		77	
929	V6	3.0 (183)	1991		KIT	P72090		76	
929	V6	3.0 (183)	1988-90		KIT	P72165		77	
Millenia		2.3 (140)	1995-96		KIT	P72165		77	
MPV	V6	2.6 (156)	1994		KIT	P72090		76	
MPV	V6	2.6 (156)	1989-93		KIT	P72165		77	
MPV	V6	3.0 (183)	1989-93		KIT	P72165		77	
MPV	V6	3.0 (183)	1995		KIT	P72165		77	
MX6	L4	2.2 (135)	1988-92		KIT	P72090		76	
MX6	L4	2.2 (135)	1990-92		KIT	P72165		77	
Protege	L4	1.8 (111)	1990-92		KIT	P72165		77	
RX7	L4	1.3 (79)	1984-85		KIT	P70199		75	
RX7	L4	1.3 (79)	1986-95		KIT	P72165		77	

Gasolina

MODELO	CIL.	LTS. (PC)	AÑOS	VIN.	TIPO BOMBA	No. PARTE	OBSERVACIONES	PAG.	NOTA
--------	------	-----------	------	------	------------	-----------	---------------	------	------

Mercury

Capri	L4	1.6 (97)	1994	6	KIT	P72165		77	
Capri	L4	1.6 (97)	1991-93	6	KIT	P72165		77	
Cougar	L4	2.3 (140)	1985-86	W	KIT	P74103		84	
Cougar	V6	3.8 (232)	1985-88	3 / 1985-87, 4 / 1987-88	KIT	P74103		84	
Cougar	V8	5.0 (302)	1985-88	F	KIT	P74103		84	
Cougar	V6	3.8 (232)	1989-93	4 / 1989-93, R / 1990	KIT	P74118		86	
Cougar	V8	5.0 (302)	1991-93	T	KIT	P74118		86	
Grand Marquis	V8	4.6 (281)	1995-96	W	KIT	P74139		87	
Grand Marquis	V8	4.6 (281)	1993-94	W	KIT	P74153		88	
Sable	V6	2.5 (153)	1986	D	KIT	P74064		82	
Sable	V6	3.0 (183)	1994-95	U	KIT	P74117		86	
Sable	V6	3.8 (232)	1994-95	4	KIT	P74117		86	
Tempo	L4	2.3 (140)	1985-87	S	KIT	P74065		82	
Topaz	L4	2.3 (140)	1987	S	KIT	P74064		82	
Topaz	L4	2.3 (140)	1988-89	X	KIT	P74092		84	
Topaz	L4	2.3 (140)	1994	X	KIT	P74145		88	
Topaz	V6	3.0 (183)	1994	U	KIT	P74145		88	
Tracer	L4	1.6 (97)	1988-89	5	KIT	P72165		77	

Mitsubishi

3000GT	V6	3.0 (183)	1991-97	6G72	KIT	P72165		77	
Eclipse	L4	2.0 (121)	1992-94		KIT	P72090		76	
Mirage	L4	1.5 (92)	1989		KIT	P72165		77	
Mirage	L4	1.6 (97)	1989		KIT	P72165		77	
Precis	L4	1.5 (92)	1989-93		KIT	P72187		77	
Sigma	V6	3.0 (183)	1989-90		KIT	P72090		76	
Starion	V6	2.6 (156)	1983-89		KIT	P70199		75	
Tredia	L4	1.8 (112)	1988		KIT	P70199		75	
Tredia	L4	1.8 (112)	1983-87		KIT	P70199		75	

Nissan

240SX	L4	2.4 (146)	1989-98	KA24E	KIT	P72193		78	
240SX	L4	2.4 (146)	1989-98	KA24DE	KIT	P72193		78	
Axxess	L4	2.4 (146)	1990-91	KA24E	KIT	P72193		78	
Axxess (Canadian)	L4	2.4 (146)	1991	KA24E	KIT	P72193		78	
Maxima	V6	3.0 (183)	1993-94	VE30DE	KIT	P72193		78	

T Con Turbina // Con CLEANSCREEN

Aplicaciones por marca para vehículos importados

Gasolina

MODELO	CIL.	LTS. (PC)	AÑOS	VIN.	TIPO BOMBA	No. PARTE	OBSERVACIONES	PAG.	NOTA
--------	------	-----------	------	------	------------	-----------	---------------	------	------

Oldsmobile

Custom Cruiser	V8	5.0 (305)	1991-92	E	KIT	P74070		83	
Custom Cruiser	V8	5.7 (350)	1992	7	KIT	P74070		83	
Cutlass Ciera	V6	2.5 (151)	1982-84	R	KIT	P60292		73	
Cutlass Ciera	V6	2.5 (151)	1982-83	5	KIT	P60293		73	
Cutlass Ciera	V6	3.0 (181)	1982-84	E	KIT	P60293		73	
Cutlass Ciera	V6	2.5 (151)	1985-86	R	KIT	P60459		74	
Cutlass Ciera	V6	3.0 (181)	1985	E	KIT	P60461		74	
Cutlass Ciera	V6	2.5 (151)	1982-85	R	KIT	P60567		75	
Cutlass Ciera	V6	2.5 (151)	1985-86	R	KIT	P60852		75	
Cutlass Ciera	V6	2.8 (173)	1987-88	W	KIT	P74045		82	
Cutlass Ciera	V6	3.3 (204)	1989-92	N	KIT	P74045		82	
Cutlass Ciera	V6	3.8 (231)	1987-88	3	KIT	P74045		82	
Eighty Eight - 88	V6	3.8 (231)	1988-96		KIT	P74045		82	
Firenza	L4	2.0 (121)	1983-84	B	KIT	P60293		73	
Firenza	L4	1.8 (112)	1983-84	O	KIT	P60567		75	
Firenza	L4	2.0 (121)	1984	P	KIT	P60567		75	
Firenza	L4	1.8 (112)	1985-86	O	KIT	P60852		75	
Firenza	L4	2.0 (121)	1985-86	P	KIT	P60852		75	
Firenza	L4	2.0 (121)	1987	K	KIT	P74002		80	
Firenza	L4	2.0 (121)	1987	1	KIT	P74051		82	
LSS	V6	3.8 (231)	1996	1	KIT	P74045		82	
Ninety-Eight - 98	V6	3.0 (181)	1985		KIT	P60461		74	
Ninety-Eight - 98	V6	3.8 (231)	1988-95		KIT	P74045		82	
Omega	V6	2.5 (151)	1982-84	R	KIT	P60292		73	
Omega	V6	2.5 (151)	1982-83	5	KIT	P60293		73	
Omega	V6	2.5 (151)	1982-84	R	KIT	P60567		75	

Peugeot

505	L4	2.0 (121)	1981-87		KIT	P60424		73	
-----	----	-----------	---------	--	-----	--------	--	----	--

Plymouth

Caravelle	L4	2.2 (135)	1986-88	E	KIT	P74115		85	
Caravelle	L4	2.2 (135)	1985	D, E	KIT	P74116		85	
Colt	L4	1.6 (97)	1984	F	KIT	P70199		75	
Colt	L4	1.5 (92)	1989-90	K, X	KIT	P72165		77	
Colt	L4	1.6 (97)	1985-89	F, Y, Z	KIT	P72165		77	
Colt	L4	1.8 (112)	1989-90	T	KIT	P72165		77	
Conquest	V6	2.6 (156)	1984-86	H, N	KIT	P70199		75	
Laser	L4	1.8 (112)	1992	T	KIT	P72090		76	
Laser	L4	2.0 (121)	1990-94	U / 1990-92, F / 1993-94	KIT	P72090		76	
Sundance	L4	2.2 (135)	1987-88	E	KIT	P74115		85	
Vista	L4	2.0 (121)	1989-90	V	KIT	P72165		77	

Gasolina

MODELO	CIL.	LTS. (PC)	AÑOS	VIN.	TIPO BOMBA	No. PARTE	OBSERVACIONES	PAG.	NOTA
--------	------	-----------	------	------	------------	-----------	---------------	------	------

Pontiac

6000	V6	2.5 (151)	1986	R	KIT	P60852		75	
6000	V6	2.5 (151)	1987	R	KIT	P74002		80	
6000	V6	2.5 (151)	1988-91	R	KIT	P74051		82	
6000	V6	2.5 (151)	1982	5	KIT	P60293		73	
6000	V6	2.5 (151)	1986	R	KIT	P60459		74	
6000	V6	2.8 (173)	1985	W	KIT	P60460		74	
6000	V6	2.5 (151)	1982-85	R	KIT	P60567		75	
6000	V6	2.8 (173)	1987-89	W	KIT	P74045		82	
6000	V6	3.1 (189)	1988	T	KIT	P74045		82	
6000	V6	3.1 (189)	1990-91	T	KIT	P74045		82	
Bonneville	V6	4.3 (262)	1986	Z	KIT	P60470		74	
Bonneville	V6	4.3 (262)	1985-86	Z	KIT	P60852		75	
Bonneville	V6	3.8 (231)	1988-95	3,C / 1988, C / 1991	KIT	P74045		82	
Bonneville	V6	3.8 (231)	1988-95	L / 1992, 1 / 1993-95	KIT	P74045		82	
Fiero	V6	2.5 (151)	1984	R	KIT	P60292		73	
Fiero	V6	2.5 (151)	1984	R	KIT	P60567		75	
Firebird	V6	2.5 (151)	1982-83	F	KIT	P60293		73	
Firebird	V8	5.0 (305)	1984	G, H	KIT	P60293		73	
Firebird	V6	2.5 (151)	1983-84	2	KIT	P60567		75	
Firebird	V8	5.0 (305)	1982-83	S, 7	KIT	P60567		75	
Firebird	V6	2.5 (151)	1985-86	2	KIT	P60852		75	
Firebird	V6	3.8 (231)	1989	7	KIT	P74074		83	
Firebird	V8	5.7 (350)	1993-95	P	KIT	P74131		87	
Grand Am	V6	2.5 (151)	1985-86	U	KIT	P60852		75	
Grand Am	V6	2.5 (151)	1987	U	KIT	P74002		80	
Grand Prix	V6	4.3 (262)	1986	Z	KIT	P60852		75	
Grand Prix	V6	3.1 (189)	1994-96	M	KIT	P74037		82	
J2000	L4	1.8 (112)	1982	O	KIT	P60292		73	
J2000	L4	2.0 (121)	1983-84	B	KIT	P60293		73	
J2000	L4	1.8 (112)	1982-83	O	KIT	P60567		75	
J2000	L4	2.0 (121)	1984	P	KIT	P60567		75	
Lemans	L4	1.6 (97)	1988-93	6	KIT	P60567		75	
Lemans	L4	2.0 (121)	1989-90	K	KIT	P60567		75	
Parisienne	V6	4.3 (262)	1985-86	Z	KIT	P60470		74	
Parisienne	V6	4.3 (262)	1985-86	Z	KIT	P60852		75	
Phoenix	V6	2.5 (151)	1982	5	KIT	P60293		73	
Phoenix	V6	2.5 (151)	1982-84	R	KIT	P60567		75	
Sunbird	L4	1.8 (112)	1985-86	O	KIT	P60852		75	
Sunbird	L4	2.0 (121)	1985-86	P	KIT	P60852		75	
Sunbird	L4	2.0 (121)	1987	K	KIT	P74002		80	
Sunbird	L4	2.0 (121)	1988-91	K	KIT	P74051		82	

T Con Turbina // Con CLEANSCREEN

Aplicaciones por marca para vehículos importados

Gasolina

MODELO	CIL.	LTS. (PC)	AÑOS	VIN.	TIPO BOMBA	No. PARTE	OBSERVACIONES	PAG.	NOTA
--------	------	-----------	------	------	------------	-----------	---------------	------	------

Sterling

825	V6	2.5 (151)	1987-88		KIT	P72090		76	
827	V6	2.7 (165)	1989-91		KIT	P72090		76	

Subaru

Impreza	L4	1.8 (112)	1993-95		KIT	P72193		78	
Legacy	L4	2.2 (135)	1992-98		KIT	P72193		78	
Legacy	L4	2.2 (135)	1990-94		KIT	P72193		78	
Legacy	V6	2.5 (151)	1996		KIT	P72193		78	
SVX	V6	3.3 (204)	1992-96		KIT	P72193		78	

Suzuki

Swift	L4	1.3 (79)	1989-94		KIT	P72165		77	
Swift	L4	1.6 (97)	1992		KIT	P72165		77	

Toyota

Camry	L4	2.0 (121)	1983-84	2SELC	KIT	P70199		75	
Camry	L4	2.0 (121)	1985-86	2SELC	KIT	P72165		77	
Camry	L4	2.0 (121)	1987-91	3SFE	KIT	P72165		77	
Celica	L4	2.4 (146)	1983	22REC	KIT	P70199		75	
Celica	L4	1.6 (97)	1992-93	4AFE	KIT	P72165		77	
Celica	L4	2.0 (121)	1986	2SELC, 3SGELC	KIT	P72165		77	
Celica	L4	2.0 (121)	1986-89	3SGELC, 3SGTE, 3SFE	KIT	P72165		77	
Celica	L4	2.0 (121)	1992-93	3SGTE	KIT	P72165		77	
Celica	L4	2.2 (135)	1992-93	5SFE	KIT	P72165		77	
Celica	L4	2.2 (135)	1990-92	5SFE	KIT	P72165		77	
Celica	L4	2.4 (146)	1983-85	22REC	KIT	P72165		77	
Corolla	L4	1.6 (97)	1985-92	4AGE, 4AFE	KIT	P72165		77	
Cressida	V6	2.6 (156)	1980	4ME	KIT	P70199		75	
Cressida	V6	2.8 (173)	1981-83	5ME, 5MGE	KIT	P70199		75	
Cressida	V6	2.8 (173)	1984-88	5MGE	KIT	P72165		77	
Cressida	V6	3.0 (181)	1989-92	7MGE	KIT	P72165		77	
MR2	L4	2.2 (135)	1994	5SFE	KIT	P72090		76	
MR2	L4	1.6 (97)	1985-89	4AGELC	KIT	P72165		77	
MR2	L4	2.0 (121)	1990-95	3SGTE	KIT	P72165		77	
MR2	L4	2.2 (135)	1990-93	3SGTE	KIT	P72165		77	
Supra	V6	2.6 (156)	1979-80	4ME	KIT	P70199		75	
Supra	V6	2.8 (173)	1981-83	5ME, 5MGE	KIT	P70199		75	
Supra	V6	2.8 (173)	1984-85	5MGE	KIT	P72165		77	
Supra	V6	3.0 (181)	1986-92	7MGE, 7MGTE	KIT	P72165		77	

Gasolina

MODELO	CIL.	LTS. (PC)	AÑOS	VIN.	TIPO BOMBA	No. PARTE	OBSERVACIONES	PAG.	NOTA
--------	------	-----------	------	------	------------	-----------	---------------	------	------

Volkswagen

Cabriolet	L4	1.8 (112)	1985-89	JH	KIT	P60424		73	
Dasher	L4	1.5 (92)	1979-80	CK	KIT	P60424		73	
Dasher	L4	1.6 (97)	1977	YG	KIT	P60424		73	
Dasher	L4	1.6 (97)	1979-81	YH, YG, CR	KIT	P60424		73	
Jetta	L4	1.6 (97)	1980-86	EJ / 1980, CR / 1981-82	KIT	P60424		73	
Jetta	L4	1.7 (105)	1981-84	EN	KIT	P60424		73	
Jetta	L4	1.8 (112)	1984	JH	KIT	P60424		73	
Rabbit	L4	1.5 (92)	1977-80	CK, FX, EH	KIT	P60424		73	
Rabbit	L4	1.6 (97)	1977-84	EE / 1977, EJ / 1980	KIT	P60424		73	
Rabbit	L4	1.6 (97)	1977-84	CR / 1981-83, JK / 1984	KIT	P60424		73	
Rabbit	L4	1.7 (105)	1981-84	EN	KIT	P60424		73	
Rabbit	L4	1.8 (112)	1983	JH	KIT	P60424		73	
Scirocco	L4	1.5 (92)	1978	EH	KIT	P60424		73	
Scirocco	L4	1.6 (97)	1976-77	FN / 1976, EE / 1977	KIT	P60424		73	
Scirocco	L4	1.6 (97)	1979-80	EJ	KIT	P60424		73	
Scirocco	L4	1.7 (105)	1981-83	EN	KIT	P60424		73	
Scirocco	L4	1.8 (112)	1984-87	JH / 1984- 86, PL, JH / 1987	KIT	P60424		73	

Volvo

760	V6	2.8 (173)	1988-90	B280F	KIT	P60567		75	
------------	----	-----------	---------	-------	-----	--------	--	----	--

Bombas Electricas Universales (En Linea) 12 Volts

Hi Performace	L4, V6, V8		Todos		KIT	P4594	Gasolina c/sin plomo, diesel	72	
Todos con carburador	L4, V6, V8		Todos		KIT	P60378	Tipo Vaso	73	
Todos con carburador	L4, V6, V8		Todos		KIT	P60108	Electrónica	73	
Todos con carburador	L4, V6, V8		Todos		KIT	P60430	Filtro Doble	73	

T Con Turbina // Con CLEANSCREEN

Aplicaciones por marca para vehículos importados

Gasolina

MODELO	CIL.	LTS. (PC)	AÑOS	VIN.	TIPO BOMBA	No. PARTE	OBSERVACIONES	PAG.	NOTA
--------	------	-----------	------	------	------------	-----------	---------------	------	------

Bombas Electricas Universales (En Linea) 12 Volts

Todos con carburador	L4, V6, V8		Todos		KIT	P74019	Cilíndrica	80	
Todos con carburador	L4, V6, V8		Todos		KIT	P74020	Cilíndrica	81	
Todos con carburador	L4, V6, V8		Todos		KIT	P74029	Cilíndrica	81	
Todos con carburador	V6, V8		Todos		KIT	P60432	Tipo Facet Alta Presión	74	
Todos con carburador	L4, V6		Todos		KIT	P60433	Tipo Facet Baja Presión	74	

Aplicaciones por marca para camionetas importadas

Gasolina

MODELO	CIL.	LTS. (PC)	AÑOS	VIN.	TIPO BOMBA	No. PARTE	OBSERVACIONES	PAG.	NOTA
--------	------	-----------	------	------	------------	-----------	---------------	------	------

Buick

RAINIER	L6	4.2 (256)	2005-07	S	MÓDULO	P76217M		126	T
RAINIER	V8	5.3 (325)	2005-07	M	MÓDULO	P76217M		126	T

Cadillac

COMMERCIAL CHASSIS	V6	4.1 (250)	1985		KIT	P60567		75	
COMMERCIAL CHASSIS	V8	6.0 (368)	1980-84		KIT	P60567		75	
COMMERCIAL CHASSIS	V8	4.5 (273)	1990		KIT	P74045		82	
COMMERCIAL CHASSIS	V8	4.9 (298)	1991		KIT	P74045		82	
COMMERCIAL CHASSIS	V8	5.7 (350)	1993		KIT	P74070		83	

Chevrolet

50 SERIES	V8	6.0 (366)	1990		KIT	P60293		73	
50 SERIES	V8	6.0 (366)	1990		KIT	P74074		83	
50 SERIES	V8	7.0 (427)	1990		KIT	P74074		83	
60 SERIES	V8	6.0 (366)	1992-94		KIT	P74074		83	
60 SERIES	V8	7.0 (427)	1992-94		KIT	P74074		83	
60 Y 70 SERIES	V8	6.0 (366)	1988-90		KIT	P60293		73	
60 Y 70 SERIES	V8	7.0 (427)	1988-90		KIT	P60293		73	
6000 SERIES	V8	6.0 (366)	1988-90		KIT	P60293		73	
6000 SERIES	V8	7.0 (427)	1988-90		KIT	P60293		73	
7000 SERIES	V8	6.0 (366)	1988-90		KIT	P60293		73	
ASTRO	L4	2.5 (151)	1985-86	E	KIT	P60470		74	
ASTRO	V6	4.3 (262)	1986	Z	KIT	P60470		74	
ASTRO	L4	2.5 (151)	1985-86	E	KIT	P60852		75	
ASTRO	V6	4.3 (262)	1986	Z	KIT	P60852		75	
ASTRO	V6	4.3 (262)	1992-95	W	KIT	P74074		83	
B SERIES	V8	6.0 (366)	1993-94		KIT	P74074		83	
BLAZER	V8	5.7 (350)	1987-94	K	KIT	P74000		80	
BLAZER	V8	5.7 (350)	1987	H	KIT	P74000		80	
BLAZER	V8	5.7 (350)	1988-91	K	KIT	P74000		80	
BLAZER	V8	5.7 (350)	1994	K	KIT	P74000		80	
BLAZER	V8	5.0 (305)	1987	H	KIT	P74000		80	
BLAZER	V8	5.7 (350)	1987	K	KIT	P74000		80	
BLAZER	V6	4.3 (262)	1992-95	W	KIT	P74074		83	
BLAZER	V6	4.3 (262)	1996	W	ENSAMBLE	P74716S	4 PUERTAS	100	T
BRAVADA	V6	4.3 (262)	1991-94		KIT	P74002		80	
BRAVADA	V6	4.3 (262)	1996	W	ENSAMBLE	P74716S	4 PUERTAS	100	T

T Con Turbina // Con CLEANSCREEN

Aplicaciones por marca para camionetas importados

Gasolina

MODELO	CIL.	LTS. (PC)	AÑOS	VIN.	TIPO BOMBA	No. PARTE	OBSERVACIONES	PAG.	NOTA
Chevrolet									
C10/1500 SERIES	V6	4.3 (262)	1996-97		KIT	P74074		83	
C20/2500 SERIES	V6	4.3 (262)	1996		KIT	P74074		83	
C20/2500 SERIES	V8	7.4 (454)	1994-95		KIT	P74074		83	
C30/3500 SERIES	V8	7.4 (454)	1994-95		KIT	P74074		83	
CABALLERO	V6	4.3 (262)	1985-86	Z	KIT	P60852		75	
C-10 / C-20 SERIES 1500 / 2500	V6	4.3 (262)	1988-95	Z	ENSAMBLE	P80000S		130	
C-10 / C-20 SERIES 1500 / 2500	V6	4.3 (262)	1988-95	Z	KIT	P18000	No es un kit Universal	72	
C-20 / SERIE 2500	V8	5.7 (350)	1988-95	K	ENSAMBLE	P80000S		130	
C-20 / SERIE 2500	V8	5.7 (350)	1988-95	K	KIT	P18000	No es un kit Universal	72	
C-20 / SERIE 2500	V8	7.4 (454)	1988-95	N	ENSAMBLE	P80000S		130	
C-20 / SERIE 2500	V8	7.4 (454)	1988-95	N	KIT	P18000	No es un kit Universal	72	
CAMIONETA SAFARI	L4	2.5 (151)	1987-90		KIT	P74002		80	
CAMIONETA SERIE T 4X4	L4	2.5 (151)	1987-93		KIT	P74002		80	
CAMIONETA SERIE S 4X2	L4	2.5 (151)	1987-90		KIT	P74002		80	
CAMIONETA SONOMA	L4	2.5 (151)	1991-93		KIT	P74002		80	
COMMERCIAL CHASSIS	V8	5.0 (305)	1991-93		KIT	P74070		83	
COMMERCIAL CHASSIS	V8	5.7 (350)	1991-93		KIT	P74070		83	
EL CAMINO	V8	5.7 (350)	1985-86		KIT	P60852		75	
ENVOY	L6	4.2 (256)	2005-07	S	MÓDULO	P76217M		126	T
ENVOY	V8	5.3 (325)	2005-07	M	MÓDULO	P76217M		126	T
G-10 - 1500 PICKUP	V8	5.7 (350)	1987-96		KIT	P74000		80	
G30/3500 SERIES	V8	7.4 (454)	1994-96		KIT	P74074		83	
JIMMY	L4	2.5 (151)	1986-92		KIT	P74002		80	
JIMMY	L4	2.8 (173)	1987-92		KIT	P74002		80	
JIMMY	V6	4.3 (262)	1993		KIT	P74002		80	
JIMMY	V6	4.3 (262)	1992-94	W	KIT	P74074		83	
JIMMY	V6	4.3 (262)	1996	W	ENSAMBLE	P74716S	4 PUERTAS	100	T
JIMMY	V8	5.0 (305)	1987	H	KIT	P60852		75	
JIMMY	V8	5.7 (350)	1985-87		KIT	P60852		75	
JIMMY S15	L4	2.5 (151)	1985-86	E	KIT	P60470		74	
JIMMY S15	L4	2.5 (151)	1985-86	E	KIT	P60852		75	
JIMMY S15	V6	2.8 (173)	1986	R	KIT	P60470		74	
JIMMY S15	V6	2.8 (173)	1986	R	KIT	P60852		75	
K10/1500 SERIES	V6	4.3 (262)	1996-97		KIT	P74074		83	

T Con Turbina // Con CLEANSCREEN

Aplicaciones por marca para camionetas importadas

Gasolina

MODELO	CIL.	LTS. (PC)	AÑOS	VIN.	TIPO BOMBA	No. PARTE	OBSERVACIONES	PAG.	NOTA
--------	------	-----------	------	------	------------	-----------	---------------	------	------

Chevrolet

K20/2500 SERIES	V6	4.3 (262)	1996		KIT	P74074		83	
K20/2500 SERIES	V8	7.4 (454)	1994-95		KIT	P74074		83	
K30/3500 SERIES	V8	7.4 (454)	1994-95		KIT	P74074		83	
KODIAK	V8	6.0 (366)	1990-96		KIT	P60293		73	
KODIAK	V8	6.0 (366)	1990-96		KIT	P74074		83	
KODIAK	V8	7.0 (427)	1990-96		KIT	P60293		73	
KODIAK	V8	7.0 (427)	1990-96		KIT	P74074		83	
LUMINA APV	V6	3.1 (189)	1990-95		KIT	P74002		80	
P20/2500 SERIES	V8	6.2 (379)	1986		KIT	P60852		75	
P30/3500 SERIES	V8	6.2 (379)	1986		KIT	P60852		75	
P30/3500 SERIES	V8	7.4 (454)	1986-89		KIT	P60852		75	
P30/3500 SERIES	V8	5.7 (350)	1996		KIT	P74074		83	
P30/3500 SERIES	V8	7.4 (454)	1994-96		KIT	P74074		83	
P60/6500 SERIES	V8	6.0 (366)	1992-96		KIT	P74074		83	
P60/6500 SERIES	V8	7.0 (427)	1992-96		KIT	P74074		83	
S SERIES - 4X2	L4	2.5 (151)	1985-86		KIT	P60470		74	
S SERIES - 4X2	V6	2.8 (173)	1985-86		KIT	P60470		74	
S SERIES - 4X2	L4	2.5 (151)	1985-86		KIT	P60852		75	
S SERIES - 4X2	V6	2.8 (173)	1986-87		KIT	P60852		75	
S SERIES - 4X2	V6	4.3 (262)	1992-95		KIT	P74074		83	
S10 BLAZER	L4	2.5 (151)	1985-86	E	KIT	P60470		74	
S10 BLAZER	V6	2.8 (173)	1986	R	KIT	P60470		74	
S10 BLAZER	L4	2.5 (151)	1986-87	R	KIT	P60852		75	
S10 BLAZER	V6	2.8 (173)	1986-87	R	KIT	P60852		75	
SAFARI	L4	2.5 (151)	1986	E	KIT	P60470		74	
SAFARI	V6	4.3 (262)	1986	Z	KIT	P60470		74	
SAFARI	V6	4.3 (262)	1992-95	W	KIT	P74074		83	
SAVANA 3500	V8	5.7 (350)	1999-00	R	MÓDULO	P74914M		110	T
SAVANA 3500	V8	5.7 (350)	1999-02	R	MÓDULO	P74915M		111	T
SAVANA 3500	V8	5.7 (350)	2001-02	R	MÓDULO	P74978M		113	T
SAVANA 3500	V8	5.7 (350)	2001-02	R	MÓDULO	P74979M		113	T
SCHOOL BUS	V8	5.7 (350)	1988-89		KIT	P60293		73	
SCHOOL BUS	V8	6.0 (366)	1988-89		KIT	P60293		73	
SCHOOL BUS	V8	6.0 (366)	1994-96		KIT	P74074		83	
SCHOOL BUS	V8	7.0 (427)	1994-96		KIT	P74074		83	
SERIE S SONOMA 4X2	L4	2.2 (134)	1996	4	ENSAMBLE	P74717S		100	T
SUBURBAN C20/2500	V8	7.4 (454)	1994-96	N	KIT	P74167		88	
SUBURBAN C30/3500	V8	7.4 (454)	1994-96		KIT	P74074		83	
SUBURBAN K20/2500	V8	7.4 (454)	1994-96		KIT	P74074		83	

T Con Turbina // Con CLEANSCREEN

Aplicaciones por marca para camionetas importados

Gasolina

MODELO	CIL.	LTS. (PC)	AÑOS	VIN.	TIPO BOMBA	No. PARTE	OBSERVACIONES	PAG.	NOTA
--------	------	-----------	------	------	------------	-----------	---------------	------	------

Chevrolet

SUBURBAN K30/3500	V8	7.4 (454)	1994-96		KIT	P74074		83	
SYCLONE	V6	4.3 (262)	1991		KIT	P74074		83	
T SERIES - 4X4	L4	2.5 (151)	1985-86		KIT	P60470		74	
T SERIES - 4X4	V6	2.8 (173)	1985-86		KIT	P60470		74	
T SERIES - 4X4	L4	2.5 (151)	1985-86		KIT	P60852		75	
T SERIES - 4X4	V6	2.8 (173)	1986		KIT	P60852		75	
T SERIES - 4X4	V6	2.8 (173)	1993		KIT	P60852		75	
T SERIES - 4X4	V6	4.3 (262)	1993		KIT	P60852		75	
T SERIES - 4X4	V6	4.3 (262)	1992-95		KIT	P74074		83	
TOPKICK	V8	6.0 (366)	1994-95		KIT	P60293		73	
TOPKICK	V8	7.0 (427)	1994-95		KIT	P60293		73	
TOPKICK	V8	6.0 (366)	1991-95		KIT	P74074		83	
TOPKICK	V8	7.0 (427)	1991-95		KIT	P74074		83	
TRACKER (CANADIAN)	L4	1.0 (61)	1989-90		KIT	P72165		77	
TYPHOON	V6	4.3 (262)	1992-93		KIT	P74074		83	
YUKON	V8	5.7 (350)	1996		KIT	P74074		83	

Chrysler

B 2500	V8	5.2 (318)	1996	X	MÓDULO	P74698M		97	
B 2500	V8	5.9 (360)	1996	X	MÓDULO	P74698M		97	
CARAVAN	L4	2.4 (148)	1996-00	B	MÓDULO	P74706M		98	T
CARAVAN	L4	2.5 (153)	1991-95	K	KIT	P90634		136	
CARAVAN	L4	2.5 (153)	1989-90		ENSAMBLE	P74501H		92	
CARAVAN	L4	2.5 (153)	1989-90		KIT	P74115		85	
CARAVAN	V6	3.0 (181)	1996-00	B	MÓDULO	P74706M		98	T
CARAVAN	V6	3.0 (183)	1987-89	3	ENSAMBLE	P74501H		92	
CARAVAN	V6	3.0 (183)	1991-95	3	KIT	P90634		136	
CARAVAN	V6	3.3 (201)	1996-00	R	MÓDULO	P74706M		98	T
CARAVAN	V6	3.3 (201)	1991-95	R	KIT	P90634		136	
CARAVAN	V6	3.8 (230)	1996-99	L	MÓDULO	P74706M		98	T
D-150 C/ LINEA RETORNO	V6	3.9 (239)	1993	X	MÓDULO	P74660M		95	
D-150 C/ LINEA RETORNO	V6	3.9 (239)	1991-93	X	KIT	P74127	NO ES UN KIT UNIVERSAL	86	
D-250 C/ LINEA RETORNO	V8	5.9 (360)	1991-93	X	MÓDULO	P74660M		95	
D-250 C/ LINEA RETORNO	V6	3.9 (239)	1991-93	X	KIT	P74127	NO ES UN KIT UNIVERSAL	86	
D-350	V8	5.9 (360)	1993	X	MÓDULO	P74660M		95	
DAKOTA	L4	2.5 (153)	1994-95	G	MÓDULO	P74675M	SIN SISTEMA DE RETORNO	96	
DAKOTA	L4	2.5 (153)	1991-95	G	MÓDULO	P74654M	CON SISTEMA DE RETORNO		

T Con Turbina // Con CLEANSCREEN

Aplicaciones por marca para camionetas importadas

Gasolina

MODELO	CIL.	LTS. (PC)	AÑOS	VIN.	TIPO BOMBA	No. PARTE	OBSERVACIONES	PAG.	NOTA
--------	------	-----------	------	------	------------	-----------	---------------	------	------

Chrysler

DAKOTA	L4	2.5 (153)	1996	P	MÓDULO	P74711M	DISEÑO WALBRO	99	
DAKOTA	L4	2.5 (153)	1996	P	MÓDULO	P74675M	SIN SISTEMA DE RETORNO	96	
DAKOTA	L4	2.5 (153)	1988-90	K	KIT	P74082		83	
DAKOTA	V6	3.9 (239)	1994-96	X	MÓDULO	P74675M	SIN SISTEMA DE RETORNO	96	
DAKOTA	V6	3.9 (239)	1991-95	X	MÓDULO	P74654M	CON SISTEMA DE RETORNO	95	
DAKOTA	V6	3.9 (239)	1996	X	MÓDULO	P74711M	DISEÑO WALBRO	99	
DAKOTA	V6	3.9 (239)	1988-90	X	KIT	P74082		83	
DAKOTA	V8	5.9 (360)	1991-95	Y	MÓDULO	P74654M	CON SISTEMA DE RETORNO	95	
DAKOTA	V8	5.9 (360)	1996	T	MÓDULO	P74711M	DISEÑO WALBRO	99	
D-150 C/ LINEA RETORNO	L4	3.9 (239)	1993	X	MÓDULO	P74660M		95	
D-150 C/ LINEA RETORNO	V6	3.9 (239)	1991-93	X	KIT	P74127	NO ES UN KIT UNIVERSAL	86	
D-250 C/ LINEA RETORNO	L4	5.9 (360)	1991-93	X	MÓDULO	P74660M		95	
D-250 C/ LINEA RETORNO	V6	3.9 (239)	1991-93	X	KIT	P74127	NO ES UN KIT UNIVERSAL	86	
D-350	V6	5.9 (360)	1993	X	MÓDULO	P74660M		95	
GRAND CARAVAN	V6	2.5 (153)	1989-90	J	ENSAMBLE	P74501H		92	
GRAND CARAVAN	V8	3.0 (183)	1987-90	3	ENSAMBLE	P74501H		92	
GRAND CARAVAN	L4	2.4 (148)	1996-97	B	MÓDULO	P74706M		98	T
GRAND CARAVAN	V6	3.0 (181)	1996-00	3	MÓDULO	P74706M		98	T
GRAND CARAVAN	L4	3.3 (201)	1996-00	R	MÓDULO	P74706M		98	T
GRAND CARAVAN	V6	3.8 (230)	1996-00	L	MÓDULO	P74706M		98	T
GRAND VOYAGER	V6	3.0 (181)	1992-95	3	MÓDULO	P74634M		94	T
GRAND VOYAGER	V6	3.0 (181)	1992-95	3	KIT	P90634		136	
GRAND VOYAGER	V6	3.3 (201)	1991-95	R	MÓDULO	P74634M		94	T
GRAND VOYAGER	V6	3.3 (201)	1991-95	R	KIT	P90634		136	
GRAND VOYAGER	V6	3.8 (230)	1994-95	L	MÓDULO	P74634M		94	T
GRAND VOYAGER	V6	3.8 (230)	1994-95	L	KIT	P90634		136	
PICK UP	V8	5.9 (360)	1988		KIT	P74082		83	
POWER RAM 50	L4	2.4 (146)	1990	W	KIT	P72165		77	
POWER RAM 50	V6	3.0 (181)	1990	S	KIT	P72165		77	
POWER RAM 50	L4	2.4 (146)	1991-93	W, G	KIT	P72242		79	
RAM 50	L4	2.4 (146)	1990	W	KIT	P72165		77	
RAM 50	V6	3.0 (181)	1990	S	KIT	P72165		77	
RAIDER	V6	3.0 (181)	1989	S	KIT	P72165		77	
TOWN & COUNTRY	L4	2.2 (135)	1986-88	E	KIT	P74115		85	
TOWN & COUNTRY	V6	3.3 (201)	1991-93	R	MÓDULO	P74634M	Tracción Delantera (FWD)	94	T
TOWN & COUNTRY	V6	3.3 (201)	1991-93	R	KIT	P90634	Tracción Delantera (FWD)	136	
TOWN & COUNTRY	V6	3.8 (230)	1994-95	L	MÓDULO	P74634M	Tracción Delantera (FWD)	94	T
TOWN & COUNTRY	V6	3.8 (230)	1994-95	L	KIT	P90634	Tracción Delantera (FWD)	136	
VAN 350	V8	5.2 (318)	1992-95	Y	MÓDULO	P74658M		95	

T Con Turbina // Con CLEANSCREEN

Aplicaciones por marca para camionetas importados

Gasolina

MODELO	CIL.	LTS. (PC)	AÑOS	VIN.	TIPO BOMBA	No. PARTE	OBSERVACIONES	PAG.	NOTA
--------	------	-----------	------	------	------------	-----------	---------------	------	------

Chrysler

VAN 350	V8	5.9 (360)	1992-95	X	MÓDULO	P74658M		95	
VOYAGER	L4	2.4 (148)	2001-02	B	MÓDULO	P75026M		115	T
VOYAGER	L4	2.4 (148)	1996-00	B	MÓDULO	P74706M		98	T
VOYAGER	V6	3.0 (181)	1991-95	R	MÓDULO	P74634M	Tracción Delantera (FWD)	94	T
VOYAGER	V6	3.0 (181)	1991-95	J	KIT	P90634		136	
VOYAGER	V6	3.3 (201)	1991-95	R	MÓDULO	P74634M	Tracción Delantera (FWD)	94	T
VOYAGER	V6	3.3 (201)	1991-95	R	KIT	P90634	Tracción Delantera (FWD)	136	

Ford

AEROSTAR	L4	2.3 (140)	1986	A	KIT	P74067		83	
BRONCO II	V6	2.9 (177)	1986-88	T	KIT	P74069		83	
E-200	V8	5.0 (302)	1988-91	N	KIT	P74067		83	
E-200	V8	7.5 (460)	1988-91	G	KIT	P74067		83	
E-200	V8	5.8 (351)	1986-91	H	KIT	P74067		83	
E-250	L6	4.9 (300)	1987-91	Y	KIT	P74067		83	
E-250	V8	5.0 (302)	1988-91	N	KIT	P74067		83	
E-250	V8	5.8 (351)	1988-91	H	KIT	P74067		83	
E-250	L6	7.5 (460)	1986-91	G	KIT	P74067		83	
E-350	L6	4.9 (300)	1992-96	Y	KIT	P74107		84	T
EXPLORER	V6	4.0 (244)	1997-98	E, X	KIT	P74178		89	
EXPLORER	V8	5.0 (302)	1998	P	KIT	P74178		89	
EXPLORER	V6	4.0 (244)	1997-98	E, X	ENSAMBLE	P74805S		105	T
EXPLORER	V8	5.0 (302)	1997-98	P	ENSAMBLE	P74805S		105	T
EXPLORER	V6	4.0 (244)	1991-94	X	ENSAMBLE	P74611S		93	
F150 SERIES	L6	4.9 (300)	1990-96	Y	KIT	P74108		85	T
F150 SERIES	V8	5.0 (302)	1990-96	N	KIT	P74108		85	T
F150 SERIES	V8	5.8 (351W)	1990-96	H	KIT	P74108		85	T
F200/250 SERIES	L6	4.9 (300)	1990-96	Y	KIT	P74108		85	T
F200/250 SERIES	V8	5.0 (302)	1990-96	N	KIT	P74108		85	T
F200/250 SERIES	V8	5.8 (351W)	1990-96	H	KIT	P74108		85	T
F200/250 SERIES	V8	7.5 (460)	1990-96	G	KIT	P74108		85	T
F300/350 SERIES	L6	4.9 (300)	1990-96	Y	KIT	P74108		85	T
F300/350 SERIES	V8	5.8 (351W)	1990-96	H	KIT	P74108		85	T
F300/350 SERIES	V8	7.5 (460)	1990-97	G	KIT	P74108		85	T
RANGER	V6	2.9 (177)	1986-88	T	KIT	P74069		83	
WINDSTAR	V6	3.0 (183)	1997-98	U	KIT	P74194		90	
WINDSTAR	V6	3.0 (183)	1996	U	KIT	P74118		86	
WINDSTAR	V6	3.8 (232)	1998	4	KIT	P74194		90	
WINDSTAR	V6	3.8 (232)	1996	4	KIT	P74118		86	

GEO

PRIZM	L4	1.6 (97)	1989-92	6, 5	KIT	P72165		77	
SPECTRUM	L4	1.5 (92)	1989	9	KIT	P72165		77	
TRACKER	L4	1.6 (97)	1992-95	6, U	KIT	P74045		82	

T Con Turbina // Con CLEANSCREEN

Aplicaciones por marca para camionetas importadas

Gasolina

MODELO	CIL.	LTS. (PC)	AÑOS	VIN.	TIPO BOMBA	No. PARTE	OBSERVACIONES	PAG.	NOTA
--------	------	-----------	------	------	------------	-----------	---------------	------	------

GMC

50 SERIES	V8	6.0 (366)	1990		KIT	P60293		73	
50 SERIES	V8	6.0 (366)	1990		KIT	P74074		83	
50 SERIES	V8	7.0 (427)	1990		KIT	P74074		83	
60 SERIES	V8	6.0 (366)	1992-94		KIT	P74074		83	
60 SERIES	V8	7.0 (427)	1992-94		KIT	P74074		83	
6000 SERIES	V8	6.0 (366)	1988-90		KIT	P60293		73	
6000 SERIES	V8	7.0 (427)	1988-90		KIT	P60293		73	
7000 SERIES	V8	6.0 (366)	1988-90		KIT	P60293		73	
B SERIES	V8	6.0 (366)	1993-94		KIT	P74074		83	
C-1500 PICKUP	V8	5.7 (350)	1997	R	ENSAMBLE	P80001S		130	T
C-1500 PICKUP	V8	5.0 (305)	1996-97	M	ENSAMBLE	P80001S		130	T
C-1500	V8	5.0 (302)	1996-97	M	KIT	P74167		88	
C15/1500 SERIES	V6	4.3 (262)	1996-97		KIT	P74074		83	
C25/2500 SERIES	V6	4.3 (262)	1996-97		KIT	P74074		83	
C25/2500 SERIES	V8	7.4 (454)	1994-95		KIT	P74074		83	
C35/3500 SERIES	V8	7.4 (454)	1994-95		KIT	P74074		83	
CABALLERO	V6	4.3 (262)	1985-86	Z	KIT	P60852		75	
G35/3500 SERIES	V8	7.4 (454)	1994-96		KIT	P74074		83	
JIMMY S15	L4	2.5 (151)	1985-86	E	KIT	P60470		74	
JIMMY S15	V6	2.8 (173)	1986	R	KIT	P60470		74	
JIMMY S15	L4	2.5 (151)	1985-86	E	KIT	P60852		75	
JIMMY S15	V6	2.8 (173)	1986	R	KIT	P60852		75	
JIMMY	V8	5.0 (305)	1987	H	KIT	P60852		75	
JIMMY	V8	5.7 (350)	1985-87		KIT	P60852		75	
JIMMY	V6	4.3 (262)	1992-94	W	KIT	P74074		83	
K15/1500 SERIES	V6	4.3 (262)	1996-97		KIT	P74074		83	
K25/2500 SERIES	V6	4.3 (262)	1996-97		KIT	P74074		83	
K25/2500 SERIES	V8	7.4 (454)	1994-95		KIT	P74074		83	
K35/3500 SERIES	V8	7.4 (454)	1994-95		KIT	P74074		83	
KODIAK	V8	6.0 (366)	1991-95		KIT	P60293		73	
KODIAK	V8	7.0 (427)	1991-95		KIT	P60293		73	
KODIAK	V8	6.0 (366)	1991-95		KIT	P74074		83	
KODIAK	V8	7.0 (427)	1991-95		KIT	P74074		83	
P25/2500 SERIES	V8	6.2 (379)	1985-87		KIT	P60852		75	
P35/3500 SERIES	V8	6.2 (379)	1985-87		KIT	P60852		75	
P35/3500 SERIES	V8	7.4 (454)	1986-89		KIT	P60852		75	
P35/3500 SERIES	V8	7.4 (454)	1994-96		KIT	P74074		83	
P65/6500 SERIES	V8	6.0 (366)	1992-96		KIT	P74074		83	
P65/6500 SERIES	V8	7.0 (427)	1992-96		KIT	P74074		83	
S SERIES - 4X2	L4	2.5 (151)	1985-86		KIT	P60470		74	
S SERIES - 4X2	V6	2.8 (173)	1985-86		KIT	P60470		74	
S SERIES - 4X2	L4	2.5 (151)	1985-86		KIT	P60852		75	
S SERIES - 4X2	V6	2.8 (173)	1985-86		KIT	P60852		75	

T Con Turbina // Con CLEANSCREEN

Aplicaciones por marca para camionetas importados

Gasolina

MODELO	CIL.	LTS. (PC)	AÑOS	VIN.	TIPO BOMBA	No. PARTE	OBSERVACIONES	PAG.	NOTA
--------	------	-----------	------	------	------------	-----------	---------------	------	------

GMC

S SERIES - 4X2	V6	4.3 (262)	1992-95			KIT	P74074		83
SAFARI	L4	2.5 (151)	1985-86	E		KIT	P60852		75
SAFARI	V6	4.3 (262)	1986	Z		KIT	P60852		75
SAFARI	V6	4.3 (262)	1992-95	W		KIT	P74074		83
SCHOOL BUS	V8	5.7 (350)	1988-90			KIT	P60293		73
SCHOOL BUS	V8	6.0 (366)	1990-96			KIT	P74074		83
SCHOOL BUS	V8	7.0 (427)	1994-96			KIT	P74074		83
SUBURBAN C25/2500	V8	7.4 (454)	1994-96			KIT	P74074		83
SUBURBAN C35/3500	V8	7.4 (454)	1994-96			KIT	P74074		83
SUBURBAN K25/2500	V8	7.4 (454)	1994-96			KIT	P74074		83
SUBURBAN K35/3500	V8	7.4 (454)	1994-96			KIT	P74074		83
SYCLONE	V6	4.3 (262)	1991			KIT	P74074		83
T SERIES - 4X4	L4	2.5 (151)	1985-86			KIT	P60852		75
T SERIES - 4X4	V6	2.8 (173)	1985-86			KIT	P60852		75
T SERIES - 4X4	V6	4.3 (262)	1992-95			KIT	P74074		83
T SERIES - 4X4	L4	2.5 (151)	1985-86			KIT	P60470		74
T SERIES - 4X4	V6	2.8 (173)	1985-86			KIT	P60470		74
TOP KICK	V8	6.0 (366)	1990-98			KIT	P60293		73
TOP KICK	V8	7.0 (427)	1990-98			KIT	P60293		73
TOP KICK	V8	6.0 (366)	1990-98			KIT	P74074		83
TOP KICK	V8	7.0 (427)	1990-98			KIT	P74074		83
TYPHOON	V6	4.3 (262)	1992-93			KIT	P74074		83
YUKON	V8	5.7 (350)	1996			KIT	P74074		83

Honda

ODYSSEY	L4	2.2 (135)	1995-97	F22B6		KIT	P72241		79
ODYSSEY	L4	2.3 (140)	1998	F23A7		KIT	P72241		79

Isuzu

PICKUP	L4	2.3 (140)	1995			KIT	P72193		78
PICKUP	L4	2.6 (156)	1995			KIT	P72193		78
RODEO	L4	2.6 (156)	1991-93			KIT	P72193		78
RODEO	V6	3.2 (195)	1994-95			KIT	P72193		78
TROOPER	V6	3.2 (195)	1992-93			KIT	P72193		78

Jeep

CHEROKEE	L4	2.4 (146)	1986-90			KIT	P74032		81
CHEROKEE	L4	2.4 (146)	1991-93			KIT	P74057		82
CHEROKEE	V6	4.0 (243)	1987-88	M		KIT	P74057		82
CHEROKEE	V6	4.0 (243)	1989-90	L		KIT	P74057		82

T Con Turbina // Con CLEANSCREEN

Gasolina

MODELO	CIL.	LTS. (PC)	AÑOS	VIN.	TIPO BOMBA	No. PARTE	OBSERVACIONES	PAG.	NOTA
--------	------	-----------	------	------	------------	-----------	---------------	------	------

Jeep

CHEROKEE	V6	4.0 (243)	1991-93	S	KIT	P74057		82	
COMANCHE	L4	2.4 (146)	1986-90		KIT	P74032		81	
COMANCHE	L4	2.4 (146)	1988-93		KIT	P74057		82	
COMANCHE	V6	4.0 (243)	1987-88	M	KIT	P74057		82	
COMANCHE	V6	4.0 (243)	1989-90	L	KIT	P74057		82	
COMANCHE	V6	4.0 (243)	1991-92	S	KIT	P74057		82	
WAGONEER	L4	2.4 (146)	1987-89		KIT	P74032		81	
WAGONEER	V6	4.0 (243)	1987-88	M	KIT	P74057		82	
WAGONEER	V6	4.0 (243)	1989-90	L	KIT	P74057		82	
WRANGLER	V6	4.0 (243)	1991-93	S	KIT	P74057		82	

Lexus

ES250	L4	2.5 (151)	1991	2VZFE	KIT	P72165		77	
LS400	V6	4.0 (243)	1991-98	1UZFE	KIT	P72165		77	

Lincoln

CONTINENTAL	V8	5.0 (302)	1985-87	F	KIT	P74103		84	
CONTINENTAL	V6	3.8 (232)	1988-94	4	KIT	P74117		86	
MARK SERIES	V8	5.0 (302)	1985	F	KIT	P74103		84	
MARK SERIES	V8	5.0 (302)	1986-87	M, F	KIT	P74103		84	
TOWN CAR	V6	4.6 (281)	1995-96	W	KIT	P74139		87	
TOWN CAR	V6	4.6 (281)	1993-94	W	KIT	P74153		88	

Mazda

323	L4	1.6 (97)	1986-92		KIT	P72165		77	
626	L4	2.0 (121)	1986-87		KIT	P72165		77	
626	L4	2.2 (135)	1988-92		KIT	P72165		77	
929	V6	3.0 (183)	1991		KIT	P72090		76	
929	V6	3.0 (183)	1988-90		KIT	P72165		77	
MILLENNIA	L4	2.3 (140)	1995-96		KIT	P72165		77	
MPV	V6	2.6 (156)	1994		KIT	P72090		76	
MPV	V6	2.6 (156)	1989-93		KIT	P72165		77	
MPV	V6	3.0 (183)	1989-93		KIT	P72165		77	
MPV	V6	3.0 (183)	1995		KIT	P72165		77	
MX6	L4	2.2 (135)	1988-92		KIT	P72090		76	
MX6	L4	2.2 (135)	1990-92		KIT	P72165		77	
NAVAJO V6 CIL.	V6	4.0 (244)	1991-94		KIT	P74123		86	
NAVAJO V6 CIL.	V6	4.0 (244)	1991-94		ENSAMBLE	P74611S		93	
PICKUP - B2200	L4	2.2 (135)	1990-93		KIT	P72090		76	
PICKUP - B2200	L4	2.2 (135)	1990-91		KIT	P72165		77	
PICKUP - B2200	L4	2.2 (135)	1987-92	W	KIT	P72137		76	
PICKUP - B2300	L4	2.3 (140)	1994-97		KIT	P74123		86	
PICKUP - B2600	V6	2.6 (156)	1990-93		KIT	P72090		76	
PICKUP - B2600	V6	2.6 (156)	1989-91		KIT	P72165		77	
PICKUP - B2600	V6	2.6 (156)	1987-88		KIT	P72137		76	

T Con Turbina // Con CLEANSCREEN

Aplicaciones por marca para camionetas importados

Gasolina

MODELO	CIL.	LTS. (PC)	AÑOS	VIN.	TIPO BOMBA	No. PARTE	OBSERVACIONES	PAG.	NOTA
--------	------	-----------	------	------	------------	-----------	---------------	------	------

Mazda

PICKUP - B3000	V6	3.0 (183)	1994-96		KIT	P74123		86	
PICKUP - B4000	L4	2.0 (121)	1994-97		KIT	P74123		86	
PROTEGE	L4	1.8 (109.5)	1990-92		KIT	P72165		77	
RX7	L4	1.3 (79)	1984-85		KIT	P70199		75	
RX7	L4	1.3 (79)	1986-95		KIT	P72165		77	

Mercury

TRACER	L4	1.6 (97)	1988-89	5	KIT	P72165		77	
--------	----	----------	---------	---	-----	--------	--	----	--

Mitsubishi

MONTERO	V6	3.0 (183)	1989-91		KIT	P72165		77	
MONTERO	V6	3.0 (183)	1992-93		KIT	P72192		77	
MONTERO	V6	3.0 (183)	1994-96		KIT	P72242		79	
MONTERO	V6	3.5 (215)	1997-99	6G74	KIT	P72242		79	
VAN	L4	2.4 (146)	1987-90		KIT	P72165		77	

Nissan

AXCESS	L4	2.4 (146)	1990-91	KA24E	KIT	P72193		78	
AXCESS (CANADIAN)	L4	2.4 (146)	1991	KA24E	KIT	P72193		78	
HD TRUCK	L4	2.4 (146)	1986-89		KIT	P72068		76	
HD TRUCK	V6	3.0 (183)	1986-89		KIT	P72068		76	
PATHFINDER	L4	2.4 (146)	1987-88	Z24I	KIT	P72060		75	
PATHFINDER	V6	3.0 (183)	1987-89	VG30I	KIT	P72060		75	
PATHFINDER	V6	3.0 (183)	1990-95	VG30E	KIT	P72060		75	
PICK-UP	V6	3.0 (183)	1995	VG30E	KIT	P72068		76	
INFINITI QX4	V6	3.5 (215)	2001-03	VQ35DE	KIT	P76036		121	

Oldsmobile

BRAVADA	V6	4.3 (262)	1992-94	W	KIT	P74074		83	
CUSTOM CRUISER	V8	5.0 (305)	1991-92	E	KIT	P74070		83	
CUSTOM CRUISER	V8	5.7 (350)	1992	7	KIT	P74070		83	
SILHOUETTE	V6	3.4 (207)	2001		MÓDULO	P74987M		113	T

Plymouth

CARAVELLE	L4	2.2 (135)	1986-88	E	KIT	P74115		85	
CARAVELLE	L4	2.2 (135)	1985	D, E	KIT	P74116		85	
COLT	L4	1.6 (97)	1984	F	KIT	P70199		75	
COLT	L4	1.5 (92)	1989-90	K, X	KIT	P72165		77	
COLT	L4	1.6 (97)	1985-89	F, Y, Z	KIT	P72165		77	
COLT	L4	1.8 (112)	1989-90	T	KIT	P72165		77	
CONQUEST	L4	2.6 (156)	1984-86	H, N	KIT	P70199		75	
LASER	L4	1.8 (112)	1992	T	KIT	P72090		76	
LASER	L4	2.0 (121)	1990-92	U	KIT	P72090		76	
LASER	L4	2.0 (121)	1993-94	F	KIT	P72090		76	
SUNDANCE	L4	2.2 (135)	1987-88	E	KIT	P74115		85	
VISTA	L4	2.0 (121)	1989-90	V	KIT	P72165		77	

Gasolina

MODELO	CIL.	LTS. (PC)	AÑOS	VIN.	TIPO BOMBA	No. PARTE	OBSERVACIONES	PAG.	NOTA
--------	------	-----------	------	------	------------	-----------	---------------	------	------

Pontiac

J2000	L4	1.8 (112)	1982	O	KIT	P60292		73	
J2000	L4	2.0 (121)	1983-84	B	KIT	P60293		73	
J2000	L4	1.8 (112)	1982-83	O	KIT	P60567		75	
J2000	L4	2.0 (121)	1984	P	KIT	P60567		75	
LEMANS	L4	1.6 (97)	1988-93	6	KIT	P60567		75	
LEMANS	L4	2.0 (121)	1989-90	K	KIT	P60567		75	
PARISIENNE	V6	4.3 (262)	1985-86	Z	KIT	P60470		74	
PARISIENNE	V6	4.3 (262)	1985-86	Z	KIT	P60852		75	
PHOENIX	L4	2.5 (151)	1982	5	KIT	P60293		73	
PHOENIX	L4	2.5 (151)	1982-84	R	KIT	P60567		75	
SUNBIRD	L4	1.8 (112)	1985-86	O	KIT	P60852		75	
SUNBIRD	L4	2.0 (121)	1985-86	P	KIT	P60852		75	
SUNBIRD	L4	2.0 (121)	1987	K	KIT	P74002		80	
SUNBIRD	L4	2.0 (121)	1988-91	K	KIT	P74051		82	

Sterling

825	L4	2.5 (151)	1987-88		KIT	P72090		76	
827	V6	2.7 (165)	1989-91		KIT	P72090		76	

Subaru

IMPREZA	L4	1.8 (112)	1993-95		KIT	P72193		78	
LEGACY	L4	2.2 (135)	1992-98		KIT	P72193		78	
LEGACY	L4	2.2 (135)	1990-94		KIT	P72193		78	
LEGACY	L4	2.5 (151)	1996		KIT	P72193		78	
SVX	V6	3.3 (204)	1992-96		KIT	P72193		78	

Suzuki

SAMURAI	L4	1.3 (79)	1991		KIT	P72090		76	
SAMURAI	L4	1.3 (79)	1993		KIT	P72090		76	
SAMURAI	L4	1.3 (79)	1990		KIT	P72165		77	
SAMURAI	L4	1.3 (79)	1992		KIT	P72165		77	
SIDEKICK	L4	1.6 (97)	1989-91		KIT	P72090		76	
SIDEKICK	L4	1.6 (97)	1992-94		KIT	P72165		77	

Toyota

4 RUNNER	L4	2.4 (146)	1985-89	22REC	KIT	P72165		77	
4 RUNNER	L4	2.4 (146)	1986-88	22RTEC	KIT	P72165		77	
4 RUNNER	L4	2.4 (146)	1990-91	22RE	KIT	P72165		77	
4 RUNNER	V6	3.0 (181)	1988	3VZE	KIT	P72165		77	
4 RUNNER	V6	3.0 (181)	1990-91	3VZE	KIT	P72165		77	
LAND CRUISER	V6	4.0 (243)	1988-92	3FE	KIT	P72165		77	
PICKUP	L4	2.4 (146)	1985-88	22REC	KIT	P72165		77	
PICKUP	L4	2.4 (146)	1990-91	22RE	KIT	P72165		77	

Aplicaciones por marca para camionetas importados

Gasolina

MODELO	CIL.	LTS. (PC)	AÑOS	VIN.	TIPO BOMBA	No. PARTE	OBSERVACIONES	PAG.	NOTA
--------	------	-----------	------	------	------------	-----------	---------------	------	------

Toyota

PICKUP	V6	3.0 (181)	1988-91	3VZE	KIT	P72165		77	
PREVIA	L4	2.4 (146)	1991-94	2TZFE	KIT	P72165		77	
VAN & WAGON	L4	2.0 (121)	1984-85	3YEC	KIT	P72165		77	
VAN & WAGON	L4	2.2 (135)	1986-89	4YEC	KIT	P72165		77	

Volkswagen

PICKUP	L4	1.6 (97)	1980	EJ	KIT	P60424		73	
PICKUP	L4	1.6 (97)	1981-83	CR	KIT	P60424		73	
PICKUP	L4	1.7 (105)	1981-83	EN	KIT	P60424		73	
RABBIT	L4	1.5 (92)	1977-80	CK, FX, EH	KIT	P60424		73	

Bombas Electricas Universales (En Linea) 12 Volts

Hi Performace	L4, V6, V8		Todos		KIT	P4594	Gasolina c/sin plomo, diesel	72	
Todos con carburador	L4, V6, V8		Todos		KIT	P60378	Tipo Vaso	73	
Todos con carburador	L4, V6, V8		Todos		KIT	P60108	Electrónica	73	
Todos con carburador	L4, V6, V8		Todos		KIT	P60430	Filtro Doble	73	
Todos con carburador	L4, V6, V8		Todos		KIT	P74019	Cilíndrica	80	
Todos con carburador	L4, V6, V8		Todos		KIT	P74020	Cilíndrica	81	
Todos con carburador	L4, V6, V8		Todos		KIT	P74029	Cilíndrica	81	
Todos con carburador	V6, V8		Todos		KIT	P60432	Tipo Facet Alta Presión	74	
Todos con carburador	L4, V6		Todos		KIT	P60433	Tipo Facet Baja Presión	74	

Aplicaciones por marca para motores a diesel

Diesel

MODELO	CIL.	LTS. (PC)	AÑOS	VIN.	TIPO BOMBA	No. PARTE	OBSERVACIONES	PAG.	NOTA
--------	------	-----------	------	------	------------	-----------	---------------	------	------

Bombas eléctricas en línea

Dodge

RAM R-2500 PICK UP	L6	5.9 (360)	1997-99	D	KIT	P74213		91	
RAM R-2500 PICK UP	L6	5.9 (360)	1999-03	6	KIT	P74213		91	
RAM R-3500 PICK UP	L6	5.9 (360)	1997-99	D	KIT	P74213		91	
RAM R-3500 PICK UP	L6	5.9 (360)	1999-03	6	KIT	P74213		91	
RAM 3500 PICK UP (Motor Cummins)	L6	5.9 (360)	1997-02	6 , D	KIT	P74213		91	
RAM 4000 PICK UP (Motor Cummins)	L6	5.9 (360)	1997-02	6 , D	KIT	P74213		91	

Ford

ECONOLINE E-350	V8	7.3 (445)	1998-02	F	KIT	P74221		92	
ECONOLINE E-450	V8	7.3 (445)	1998-02	F	KIT	P74221		92	
E SUPER DUTY	V8	7.3 (445)	1998-02	F	KIT	P74221		92	
EXCURSION	V8	7.3 (445)	2000-03	F	KIT	P74221		92	
F-250 SUPER DUTY PICK UP	V8	7.3 (445)	1999-02	F	KIT	P74221		92	
F-350 SUPER DUTY PICK UP	V8	7.3 (445)	1999-02	F	KIT	P74221		92	

General Motors

C-1500	V8	6.5 (395)	1994-98	F, P, S	KIT	P74143		87	
C-2500	V8	6.5 (395)	1994-98	F, S	KIT	P74143		87	
C-3500 PICKUP	V8	5.7 (350)	1996-98	R	KIT	P74143	CBT (GFT)	87	
C-3500 PICKUP	V8	6.5 (396)	1994-98	F	KIT	P74143	Bomba de transferencia	87	
C-3500 PICKUP	V8	7.4 (454)	1997-98	J	KIT	P74143	CBT (VCD, VRY, VPN, VRZ)	87	
C-3500	V8	6.5 (395)	1994-98	F, S	KIT	P74143		87	
G-35 VAN	V8	6.5 (395)	1994-98	F	KIT	P74143		87	
G-3500 VAN	V8	6.5 (395)	1994-98	F	KIT	P74143		87	
K2500	V8	6.5 (395)	1994-98	F, S	KIT	P74143		87	
K3500	V8	6.5 (395)	1994-98	F, S	KIT	P74143		87	
P-35 VAN	V8	6.5 (395)	1994-98	Y, F	KIT	P74143		87	
P-3500 VAN	V8	6.5 (395)	1994-98	Y, F	KIT	P74143		87	
Hi Performace	TODOS				KIT	P4594		72	

T Con Turbina // Con CLEANSCREEN

Aplicaciones por marca para motores a diesel

Diesel

MODELO	CIL.	LTS. (PC)	AÑOS	VIN.	TIPO BOMBA	No. PARTE	OBSERVACIONES	PAG.	NOTA
--------	------	-----------	------	------	------------	-----------	---------------	------	------

Bombas mecánicas

Cummins

Motore Cummins 6BT	L6	5.9 (359)	1994-02		MECÁNICA	M73098	Bomba Tipo DIAFRAGMA	149	
Motore Cummins 4BT	L4	3.9 (239)	1994-02		MECÁNICA	M73099	Bomba Tipo DIAFRAGMA	150	

Dodge

D250 PICK UP	L6	5.9 (359)	1989-93	8, C	MECÁNICA	M73060		149	
D350 PICK UP	L6	5.9 (359)	1989-93	8, C	MECÁNICA	M73060		149	
RAM 2500 PICK UP	L6	5.9 (359)	1994-96	C	MECÁNICA	M73104		150	
RAM 3500 PICK UP	L6	5.9 (359)	1994-96	C	MECÁNICA	M73104		150	
W250 PICK UP	L6	5.9 (359)	1989-93	8, C	MECÁNICA	M73060		149	
W350 PICK UP	L6	5.9 (359)	1989-93	8, C	MECÁNICA	M73060		149	

Ford

ECONOLINE E-350	V8	7.3 (445)	1995-98	F	MECÁNICA	M61067		144	
E SUPER DUTY	V8	7.3 (445)	1996-98	F	MECÁNICA	M61067		144	
F-250 PICK UP	V8	7.3 (445)	1994-97	F	MECÁNICA	M61067		144	
F-350 PICK UP	V8	7.3 (445)	1994-97	F	MECÁNICA	M61067		144	
F-450 SUPER DUTY PICK UP	V8	7.3 (445)	1995-97	F	MECÁNICA	M61067		144	

John Deere

TRACTOR GAS 1020			1969		MECÁNICA	M73031		149	
TRACTOR GAS 1520			1969		MECÁNICA	M73031		149	

T Con Turbina // Con CLEANSCREEN

Bombas Mecánicas

MODELO	CIL.	LTS. (PC)	AÑOS	TIPO BOMBA	No. PARTE	OBSERVACIONES	PAG.	NOTA
--------	------	-----------	------	------------	-----------	---------------	------	------

AMC

AMX	V8	5.6 (343)	1976-79	B. MECÁNICA	M6736		146	
AMX	V8	5.9 (360)	1976-79	B. MECÁNICA	M6736		146	
MATADOR	V8	5.6 (343)	1976-79	B. MECÁNICA	M6736		146	
MATADOR	V8	5.9 (360)	1976-79	B. MECÁNICA	M6736		146	
PACER	V8	5.6 (343)	1976-79	B. MECÁNICA	M6736		146	
PACER	V8	5.9 (360)	1976-79	B. MECÁNICA	M6736		146	

Chevrolet / Buick / Oldsmobile

BLAZER	V8	4.1 (250)	1976-82	B. MECÁNICA	M6738		146	
BUICK APOLLO	V8	4.1 (250)	1975	B. MECÁNICA	M6738		146	
BUICK APOLLO	V8	4.3 (260)	1975	B. MECÁNICA	M6109		145	
BUICK SKYLARK	V6	2.8 (173)	1980-81	B. MECÁNICA	M60143		140	
C-10 PICKUP	V8	4.8 (292)	1976-80	B. MECÁNICA	M6738		146	
CAMARO	V6	2.8 (173)	1982-84	B. MECÁNICA	M60280		141	
CAMARO	V6	3.8 (229)	1980-81	B. MECÁNICA	M60086		140	
CELEBRITY	V6	2.8 (173)	1983-86	B. MECÁNICA	M60335		142	
CENTURY	V6	2.8 (173)	1983-86	B. MECÁNICA	M60335		142	
CENTURY	V6	3.2 (195)	1978-79	B. MECÁNICA	M6951		147	
CENTURY	V6	3.8 (231)	1977-81	B. MECÁNICA	M6951		147	
CENTURY	V8	5.7 (350)	1973-77	B. MECÁNICA	M4641	SIN A / ACC	139	
CHEVETTE	L4	1.6 (105)	1979-87	B. MECÁNICA	M60085		140	
CITATION	L4	2.5 (1519)	1980-81	B. MECÁNICA	M60142		140	
CITATION	V6	2.8 (173)	1983-86	B. MECÁNICA	M60335		142	
CUTLASS	V6	3.8 (231)	1979-85	B. MECÁNICA	M60003		139	
CUTLASS CIERA	V6	2.8 (173)	1983-86	B. MECÁNICA	M60335		142	
ELECTRA	V8	5.0 (307)	1982-89	B. MECÁNICA	M6109		145	
ELECTRA	V8	5.7 (350)	1978-80	B. MECÁNICA	M6109		145	
FIREBIRD	V6	2.8 (173)	1982-84	B. MECÁNICA	M60280		141	
G-10 VAN	V8	5.0 (305)	1979-86	B. MECÁNICA	M60087		140	
G-10 VAN	V8	5.7 (350)	1979-86	B. MECÁNICA	M60087		140	
G-20 VAN	V8	5.0 (305)	1983-86	B. MECÁNICA	M60087		140	
G-20 VAN	V8	5.7 (350)	1979-86	B. MECÁNICA	M60087		140	
G-20 VAN	V8	6.6 (400)	1980	B. MECÁNICA	M60087		140	
IMPALA	V6	3.8 (229)	1983-84	B. MECÁNICA	M60086		140	
K10	V6	4.3 (262)	1985	B. MECÁNICA	M60477		144	
MALIBU	V6	3.8 (229)	1980-83	B. MECÁNICA	M60086		140	
MONTECARLO	V6	3.8 (231)	1979-85	B. MECÁNICA	M60003		139	
REGAL	V6	3.2 (195)	1978-79	B. MECÁNICA	M6951		147	
REGAL	V6	3.8 (231)	1979-85	B. MECÁNICA	M60003		139	
S10 BLAZER	V6	2.8 (173)	1982-83	B. MECÁNICA	M60284		141	
S10 BLAZER	V6	2.8 (173)	1984-85	B. MECÁNICA	M60404		143	
S15 JIMMY	L4	1.9 (119)	1983-85	B. MECÁNICA	M70186		148	

T Con Turbina // Con CLEANSCREEN

Bombas Mecánicas

MODELO	CIL.	LTS. (PC)	AÑOS	TIPO BOMBA	No. PARTE	OBSERVACIONES	PAG.	NOTA
--------	------	-----------	------	------------	-----------	---------------	------	------

Chevrolet / Buick / Oldsmobile

S15 JIMMY	V6	2.8 (173)	1984-85	B. MECÁNICA	M60404		143	
SUBURBAN	V8	7.4 (454)	1973-86	B. MECÁNICA	M6628		145	
TODOS CON	L6	3.7 (230)	1967-73	B. MECÁNICA	M4503		139	
TODOS CON	L6	4.0 (250)	1967-73	B. MECÁNICA	M4503		139	
TODOS CON	V8	4.3 (260)	1973-80	B. MECÁNICA	M6624		145	
TODOS CON	L6	4.8 (292)	1967-73	B. MECÁNICA	M4503		139	
TODOS CON	V8	5.0 (307)	1973-80	B. MECÁNICA	M6624		145	
TODOS CON	V8	5.7 (350)	1969-74	B. MECÁNICA	M4642		139	
TODOS CON	V8	5.7 (350)	1973-80	B. MECÁNICA	M6624		145	
TODOS CON	V8	5.7 (350)	1973-87	B. MECÁNICA	M6626	CON RETORNO	145	
TODOS CON	V8	6.5 (396)	1966-70	B. MECÁNICA	M4530		139	
TODOS CON	V8	6.6 (402)	1966-70	B. MECÁNICA	M4530		139	
TODOS CON	V8	7.5 (454)	1966-70	B. MECÁNICA	M4530		139	

Chrysler

LE BARON	L4	2.6 (156)	1982-85	B. MECÁNICA	M60509		144	
CORDOBA	V8	5.2 (318)	1975-81	B. MECÁNICA	M60514		144	
CORDOBA	V8	5.2 (318)	1977-83	B. MECÁNICA	M60519		144	
CORDOBA	V8	5.9 (360)	1975-81	B. MECÁNICA	M60514		144	
NEW PORT	V6	3.7 (225)	1979-81	B. MECÁNICA	M60577		144	

Dodge

D50 PICK UP	L4	2.0 (122)	1981-87	B. MECÁNICA	M70293		148	
D50 PICK UP	L4	2.6 (156)	1981-87	B. MECÁNICA	M70293		148	
OMNI	L4	1.7 (105)	1978-83	B. MECÁNICA	M60238		141	
TODOS CON CÓDIGO "K"	L4	2.5 (135)	1981-89	B. MECÁNICA	M60321		142	
RAM CHARGER	V8	6.6 (400)	1974-78	B. MECÁNICA	M6935		147	
RAM CHARGER	V8	7.4 (440)	1974-78	B. MECÁNICA	M6935		147	

Ford

BRONCO	L4	2.0 (122)	1984-87	B. MECÁNICA	M60328		142	
BRONCO	L4	2.3 (140)	1984-87	B. MECÁNICA	M60328		142	
BRONCO	V6	2.8 (171)	1970-74	B. MECÁNICA	M6399		145	
BRONCO	V6	3.3 (200)	1980-86	B. MECÁNICA	M60330		142	
BRONCO	V6	3.3 (200)	1970-74	B. MECÁNICA	M6399		145	
BRONCO	V6	4.0 (250)	1980-86	B. MECÁNICA	M60330		142	
BRONCO	V6	4.0 (240)	1970-74	B. MECÁNICA	M6399		145	
BRONCO	V6	4.9 (300)	1980-86	B. MECÁNICA	M60330		142	
BRONCO	V8	4.9 (298)	1975-79	B. MECÁNICA	M6962		147	
BRONCO	V8	5.0 (302)	1975-79	B. MECÁNICA	M6962		147	
BRONCO	V8	5.8 (354)	1980-87	B. MECÁNICA	M60318		142	

T Con Turbina // Con CLEANSCREEN

Bombas Mecánicas

MODELO	CIL.	LTS. (PC)	AÑOS	TIPO BOMBA	No. PARTE	OBSERVACIONES	PAG.	NOTA
--------	------	-----------	------	------------	-----------	---------------	------	------

Ford

BRONCO II	V6	2.8 (171)	1984-85	B. MECÁNICA	M60331		142	
CUSTOM 500	V8	5.7 (352)	1968-73	B. MECÁNICA	M6984		147	
CUSTOM 500	V8	6.0 (360)	1968-73	B. MECÁNICA	M6984		147	
CUSTOM 500	V8	6.4 (390)	1968-73	B. MECÁNICA	M6984		147	
ECONOLINE	V8	7.5 (457)	1977-79	B. MECÁNICA	M60036		139	
ECONOLINE 351W	V8	4.9 (298)	1975-79	B. MECÁNICA	M6962		147	
ECONOLINE 351W	V8	5.0 (302)	1975-79	B. MECÁNICA	M6962		147	
ECONOLINE 351W	V8	5.8 (354)	1980-87	B. MECÁNICA	M60318		142	
ECONOLINE 351M	V8	7.0 (400)	1980-82	B. MECÁNICA	M60185		141	
ECONOLINE 351W	V8	7.0 (400)	1980-82	B. MECÁNICA	M60185		141	
ECONOLINE E100	V8	4.9 (300)	1976-79	B. MECÁNICA	M6807		146	
F-100	V8	5.7 (352)	1968-73	B. MECÁNICA	M6984		147	
F-100	V8	6.0 (360)	1968-73	B. MECÁNICA	M6984		147	
F-100	V8	6.4 (390)	1968-73	B. MECÁNICA	M6984		147	
F-150	V6	3.3 (200)	1980-86	B. MECÁNICA	M60330		142	
F-150	V6	4.0 (250)	1980-86	B. MECÁNICA	M60330		142	
F-150	V6	4.9 (300)	1980-86	B. MECÁNICA	M60330		142	
F-150	V8	5.7 (352)	1968-73	B. MECÁNICA	M6984		147	
F-150	V8	5.9 (360)	1974-76	B. MECÁNICA	M6676		145	
F-150	V8	6.0 (360)	1968-73	B. MECÁNICA	M6984		147	
F-150	V8	6.4 (390)	1968-73	B. MECÁNICA	M6984		147	
F-150	V8	6.4 (390)	1974-76	B. MECÁNICA	M6676		145	
F-250	V8	5.7 (352)	1968-73	B. MECÁNICA	M6984		147	
F-250	V8	5.9 (360)	1974-76	B. MECÁNICA	M6676		145	
F-250	V8	6.0 (360)	1968-73	B. MECÁNICA	M6984		147	
F-250	V8	6.4 (390)	1968-73	B. MECÁNICA	M6984		147	
F-250	V8	6.4 (390)	1974-76	B. MECÁNICA	M6676		145	
F-350	V8	5.0 (302)	1976-80	B. MECÁNICA	M6750		146	
F-350	V8	5.9 (360)	1974-76	B. MECÁNICA	M6676		145	
F-350	V8	6.4 (390)	1974-76	B. MECÁNICA	M6676		145	
F-600	V8	6.1 (370)	1979-89	B. MECÁNICA	M60045		140	
F-600	V8	7.0 (426)	1979-89	B. MECÁNICA	M60045		140	
F-800	V8	6.1 (370)	1979-89	B. MECÁNICA	M60045		140	
F-800	V8	7.0 (426)	1979-89	B. MECÁNICA	M60045		140	
FAIRMONT	V8	5.0 (302)	1976-80	B. MECÁNICA	M6750		146	
GALAXIE 500	V8	5.7 (351)	1974	B. MECÁNICA	M6882	Todos con motor Cleaveland	146	
GALAXIE 500	V8	6.6 (400)	1974	B. MECÁNICA	M6882		146	
GRANADA 289	V8	5.0 (302)	1976-80	B. MECÁNICA	M6750		146	
PICK UP	V8	7.5 (457)	1977-79	B. MECÁNICA	M60036		139	
PICK UP F-100	V8	4.9 (300)	1976-79	B. MECÁNICA	M6807		146	
RANGER	L4	2.0 (122)	1983	B. MECÁNICA	M60235		141	
RANGER	L4	2.0 (122)	1984-87	B. MECÁNICA	M60328		142	
RANGER	L4	2.3 (140)	1983	B. MECÁNICA	M60235		141	
RANGER	L4	2.3 (140)	1984-87	B. MECÁNICA	M60328		142	

Bombas Mecánicas

MODELO	CIL.	LTS. (PC)	AÑOS	TIPO BOMBA	No. PARTE	OBSERVACIONES	PAG.	NOTA
--------	------	-----------	------	------------	-----------	---------------	------	------

Honda

CRX	L4	1.5 (105)	1984-87	B. MECÁNICA	M70214		148	
-----	----	-----------	---------	-------------	--------	--	-----	--

Hyundai

EXCEL	L4	1.5 (105)	1986-89	B. MECÁNICA	M70307		149	
-------	----	-----------	---------	-------------	--------	--	-----	--

International

HARVESTES CAMION	L4	5.0 (304)	1970-75	B. MECÁNICA	M6959		147	
HARVESTES CAMION	L4	5.7 (345)	1970-75	B. MECÁNICA	M6959		147	
HARVESTES CAMION	L4	6.5 (392)	1970-75	B. MECÁNICA	M6959		147	
HARVESTES CAMION	V8	5.0 (304)	1970-75	B. MECÁNICA	M6959		147	
HARVESTES CAMION	V8	5.7 (345)	1970-75	B. MECÁNICA	M6959		147	
HARVESTES CAMION	V8	6.5 (392)	1970-75	B. MECÁNICA	M6959		147	

Isuzu

AMIGO	L4	2.3 (140)	1988-94	B. MECÁNICA	M70308		149	
PICK UP	L4	2.3 (140)	1988-94	B. MECÁNICA	M70308		149	

Jeep

COMANCHE	V6	2.8 (173)	1984-85	B. MECÁNICA	M60405		143	
CHEROKEE	V6	2.8 (173)	1984-85	B. MECÁNICA	M60405		143	

Mazda

626	L4	2.0 (122)	1984-85	B. MECÁNICA	M70083		148	
PICK UP B2200	L4	2.2 (122)	1987-91	B. MECÁNICA	M70196		148	

Nissan

200SX	L4	2.0	1978-79	B. MECÁNICA	M60266		141	
DATSUN 610	L4	1.7 (105)	1974-75	B. MECÁNICA	M70111		148	
DATSUN 610	L4	2.0 (122)	1974-75	B. MECÁNICA	M70111		148	
DATSUN 710	L4	1.7 (105)	1974-75	B. MECÁNICA	M70111		148	
DATSUN 710	L4	2.0 (122)	1974-75	B. MECÁNICA	M70111		148	
SENTRA	L4	1.6 (105)	1984-88	B. MECÁNICA	M70041		147	

Suzuki

SAMURAI	L4	1.3 (100)	1986-89	B. MECÁNICA	M70319		149	
---------	----	-----------	---------	-------------	--------	--	-----	--

T Con Turbina // Con CLEANSCREEN

Bombas Mecánicas

MODELO	CIL.	LTS. (PC)	AÑOS	TIPO BOMBA	No. PARTE	OBSERVACIONES	PAG.	NOTA
--------	------	-----------	------	------------	-----------	---------------	------	------

Toyota

CELICA	L4	2.2	(122)	1980	B. MECÁNICA	M60420	20R	143	
CORONA	L4	2.2	(122)	1980	B. MECÁNICA	M60420	20R	143	
COROLLA	L4	1.8	(105)	1980-82	B. MECÁNICA	M60419	3TC	143	
PICK UP	L4	2.4	(145)	1981-90	B. MECÁNICA	M60416	22R	143	
TERCEL	L4	1.5	(105)	1980-82	B. MECÁNICA	M60418	1AC, 3AC	143	

VAM

TODOS CON	L6	3.8	(232)	1970-78	B. MECÁNICA	M6737		146	
TODOS CON	L6	4.3	(258)	1970-78	B. MECÁNICA	M6737		146	
TODOS CON	L6	4.8	(282)	1970-78	B. MECÁNICA	M6737		146	

T Con Turbina // Con CLEANSCREEN

FOTOGRAFÍAS



Carter
FUEL DELIVERY PRODUCTS

P14000



Carter
FUEL DELIVERY PRODUCTS

P18000



Carter
FUEL DELIVERY PRODUCTS

P4594



Carter
FUEL DELIVERY PRODUCTS

P54000



Carter
FUEL DELIVERY PRODUCTS

P54901



Carter
FUEL DELIVERY PRODUCTS

P54902

FOTOGRAFÍAS



P60108



P60292



P60293

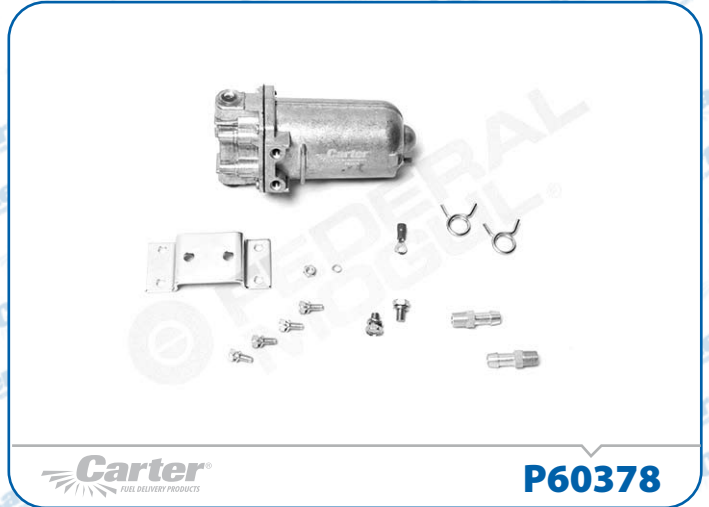

P60378



P60424



P60430

FOTOGRAFÍAS



P60432

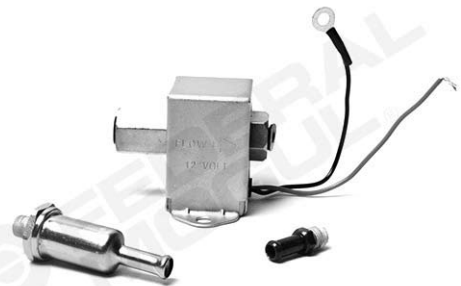

P60433



P60459



P60460



P60461



P60470

FOTOGRAFÍAS



P60488



P60567



P60852



P70199



P72024



P72060

FOTOGRAFÍAS



Carter
FUEL DELIVERY PRODUCTS

P72068



Carter
FUEL DELIVERY PRODUCTS

P72090



Carter
FUEL DELIVERY PRODUCTS

P72128



Carter
FUEL DELIVERY PRODUCTS

P72128A



Carter
FUEL DELIVERY PRODUCTS

P72137



Carter
FUEL DELIVERY PRODUCTS

P72140

FOTOGRAFÍAS



P72144



P72165



P72187



P72190



P72192



P72192A

FOTOGRAFÍAS



P72192B



P72192C



P72192D



P72193



P72193A



P72195

FOTOGRAFÍAS



P72201



P72230



P72237



P72241



P72242



P72250

FOTOGRAFÍAS



Carter
FUEL DELIVERY PRODUCTS

P72259



Carter
FUEL DELIVERY PRODUCTS

P72261



Carter
FUEL DELIVERY PRODUCTS

P74000



Carter
FUEL DELIVERY PRODUCTS

P74002



Carter
FUEL DELIVERY PRODUCTS

P74006



Carter
FUEL DELIVERY PRODUCTS

P74019

FOTOGRAFÍAS

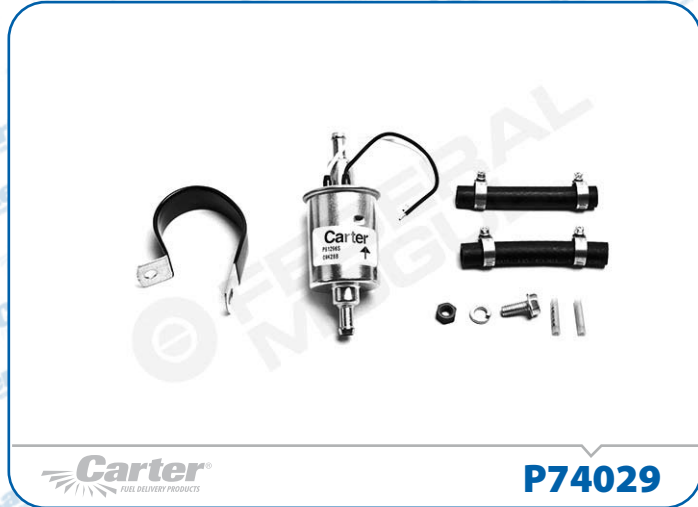
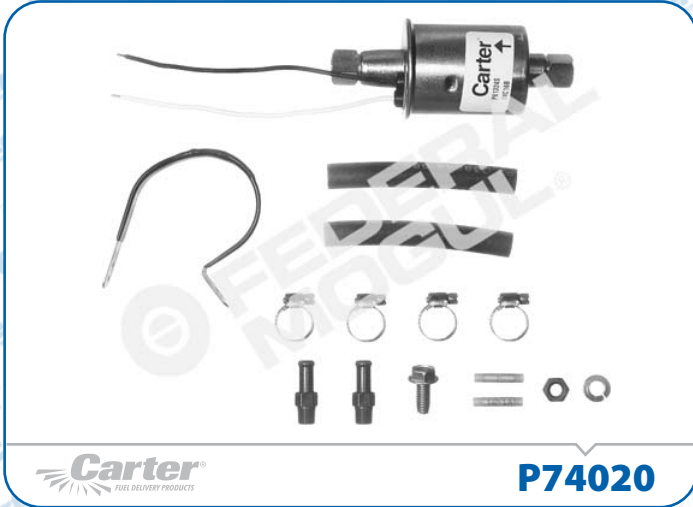

FOTOGRAFÍAS



P74037



P74045



P74051



P74057



P74064



P74065

FOTOGRAFÍAS



P74067



P74069



P74070



P74074



P74082



P74083

FOTOGRAFÍAS



P74092



P74095



P74096



P74103



P74104



P74107

FOTOGRAFÍAS



P74108



P74109



P74111



P74112



P74115



P74116

FOTOGRAFÍAS



Carter®
FUEL DELIVERY PRODUCTS

P74117



Carter®
FUEL DELIVERY PRODUCTS

P74118



Carter®
FUEL DELIVERY PRODUCTS

P74119



Carter®
FUEL DELIVERY PRODUCTS

P74122



Carter®
FUEL DELIVERY PRODUCTS

P74123



Carter®
FUEL DELIVERY PRODUCTS

P74127

FOTOGRAFÍAS



P74128



P74129



P74131



P74139



P74143

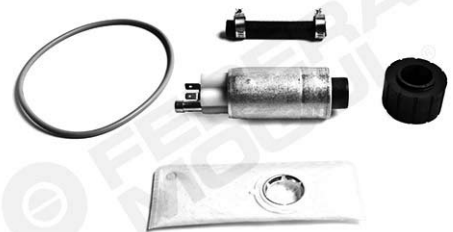

P74144

FOTOGRAFÍAS



Carter
FUEL DELIVERY PRODUCTS

P74145



Carter
FUEL DELIVERY PRODUCTS

P74153

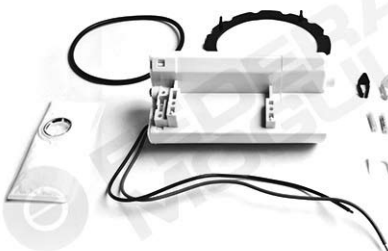

Carter
FUEL DELIVERY PRODUCTS

P74159



Carter
FUEL DELIVERY PRODUCTS

P74167



Carter
FUEL DELIVERY PRODUCTS

P74169



Carter
FUEL DELIVERY PRODUCTS

P74170

FOTOGRAFÍAS



P74172



P74176



P74177



P74178



P74186



P74188

FOTOGRAFÍAS



Carter
FUEL DELIVERY PRODUCTS

P74189



Carter
FUEL DELIVERY PRODUCTS

P74191



Carter
FUEL DELIVERY PRODUCTS

P74194



Carter
FUEL DELIVERY PRODUCTS

P74199



Carter
FUEL DELIVERY PRODUCTS

P74201



Carter
FUEL DELIVERY PRODUCTS

P74203

FOTOGRAFÍAS



P74207



P74208



P74210



P74211



P74212



P74213

FOTOGRAFÍAS



Carter
FUEL DELIVERY PRODUCTS

P74221



Carter
FUEL DELIVERY PRODUCTS

P74222



Carter
FUEL DELIVERY PRODUCTS

P74501H



Carter
FUEL DELIVERY PRODUCTS

P74502H



Carter
FUEL DELIVERY PRODUCTS

P74527S



Carter
FUEL DELIVERY PRODUCTS

P74528S

FOTOGRAFÍAS

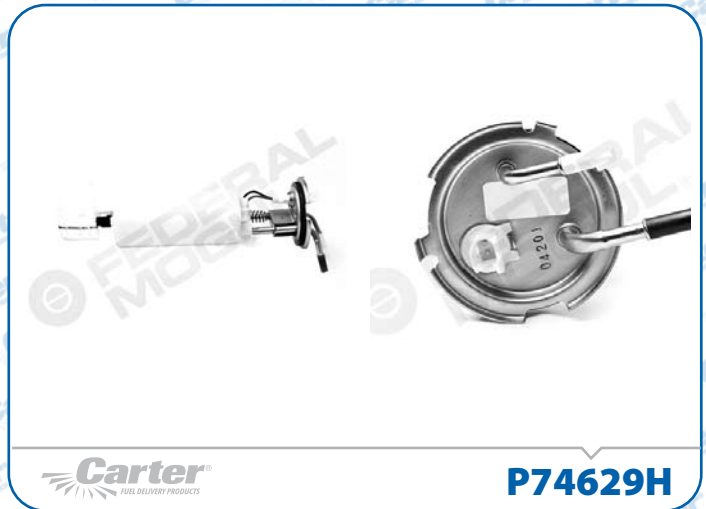
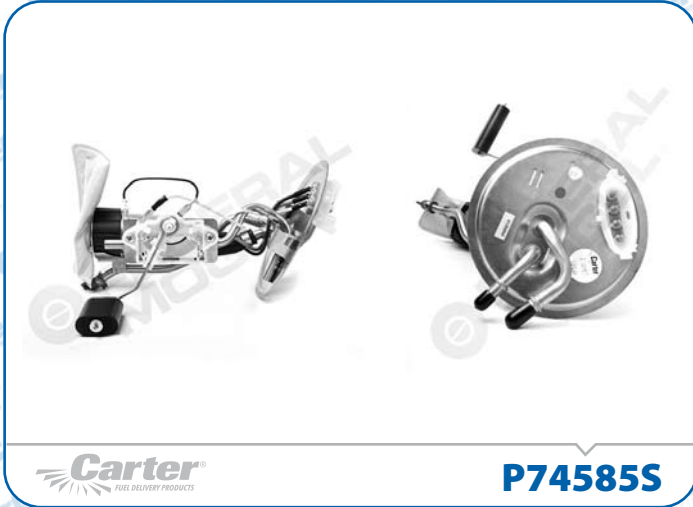

FOTOGRAFÍAS



Carter
FUEL DELIVERY PRODUCTS

P74631



Carter
FUEL DELIVERY PRODUCTS

P74634M



Carter
FUEL DELIVERY PRODUCTS

P74635H



Carter
FUEL DELIVERY PRODUCTS

P74643S



Carter
FUEL DELIVERY PRODUCTS

P74651S



Carter
FUEL DELIVERY PRODUCTS

P74653M

FOTOGRAFÍAS



P74654M



P74655M



P74656M



P74658M



P74660M



P74662M

FOTOGRAFÍAS



P74663M



P74668H



P74673M



P74675M



P74676M



P74682M

FOTOGRAFÍAS



Carter®
FUEL DELIVERY PRODUCTS

P74688M

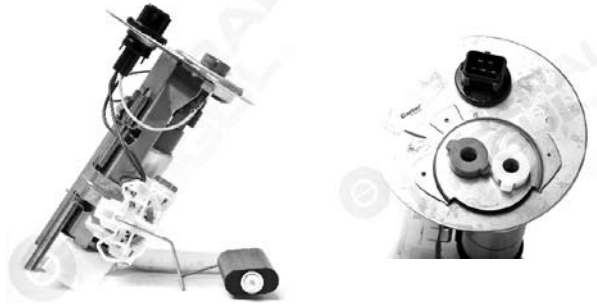

Carter®
FUEL DELIVERY PRODUCTS

P74689S

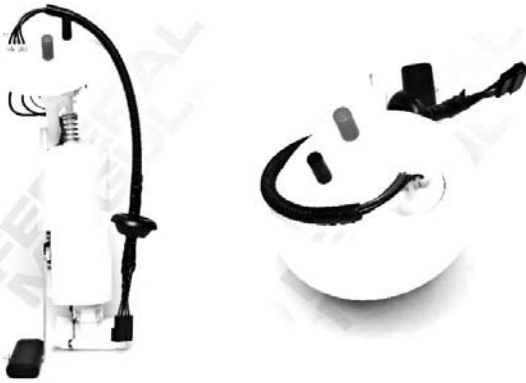

Carter®
FUEL DELIVERY PRODUCTS

P74693M



Carter®
FUEL DELIVERY PRODUCTS

P74695M



Carter®
FUEL DELIVERY PRODUCTS

P74697M



Carter®
FUEL DELIVERY PRODUCTS

P74698M

FOTOGRAFÍAS



Carter
FUEL DELIVERY PRODUCTS

P74701M



Carter
FUEL DELIVERY PRODUCTS

P74702M



Carter
FUEL DELIVERY PRODUCTS

P74703M



Carter
FUEL DELIVERY PRODUCTS

P74705M



Carter
FUEL DELIVERY PRODUCTS

P74706M



Carter
FUEL DELIVERY PRODUCTS

P74707M

FOTOGRAFÍAS

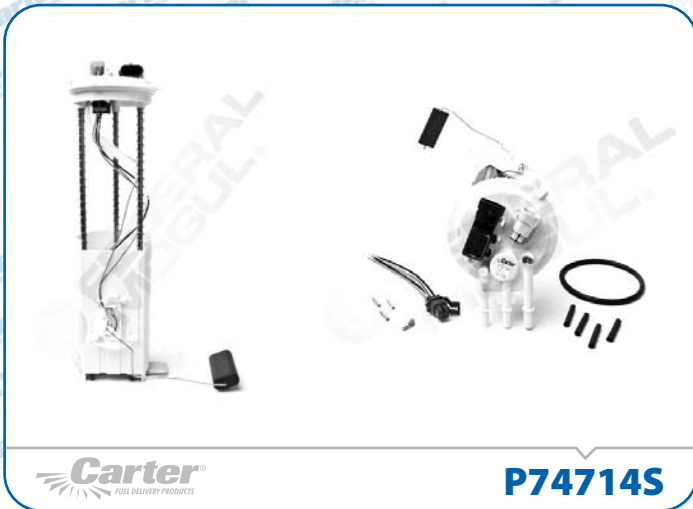

FOTOGRAFÍAS



Carter
FUEL DELIVERY PRODUCTS

P74716S



Carter
FUEL DELIVERY PRODUCTS

P74717S



Carter
FUEL DELIVERY PRODUCTS

P74723H



Carter
FUEL DELIVERY PRODUCTS

P74724H



Carter
FUEL DELIVERY PRODUCTS

P74728H



Carter
FUEL DELIVERY PRODUCTS

P74732M

FOTOGRAFÍAS



FOTOGRAFÍAS

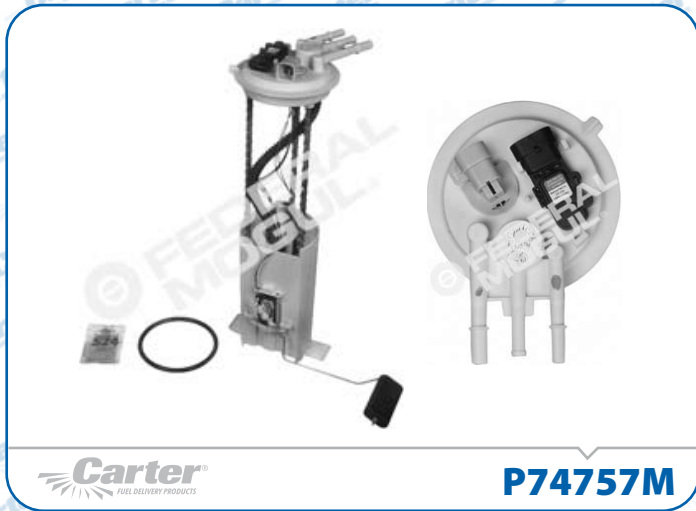

FOTOGRAFÍAS

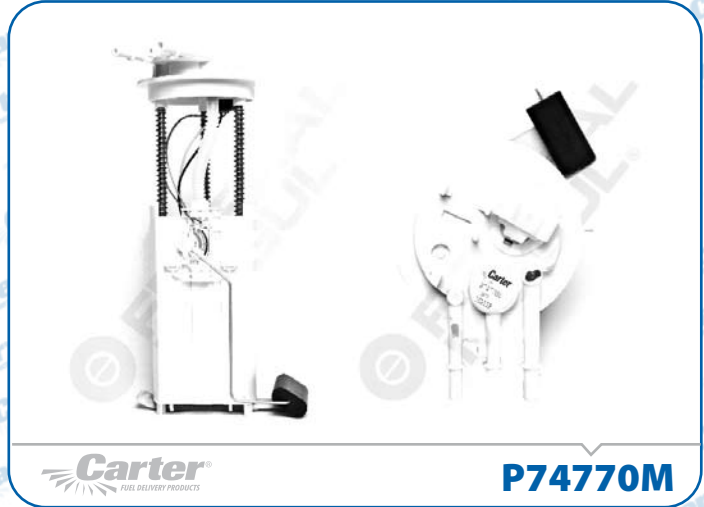
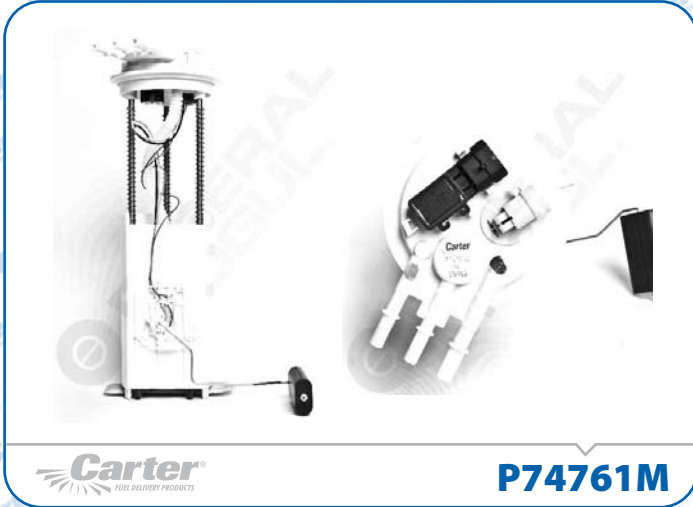

FOTOGRAFÍAS



Carter®
FUEL DELIVERY PRODUCTS

P74782M



Carter®
FUEL DELIVERY PRODUCTS

P74789M



Carter®
FUEL DELIVERY PRODUCTS

P74790M

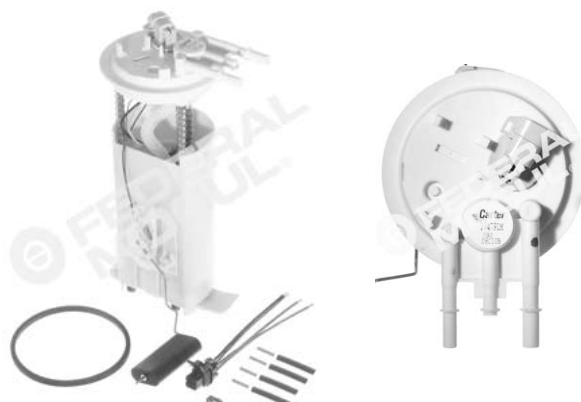

Carter®
FUEL DELIVERY PRODUCTS

P74791M



Carter®
FUEL DELIVERY PRODUCTS

P74792M



Carter®
FUEL DELIVERY PRODUCTS

P74794M

FOTOGRAFÍAS



Carter®
FUEL DELIVERY PRODUCTS

P74800M



Carter®
FUEL DELIVERY PRODUCTS

P74801M



Carter®
FUEL DELIVERY PRODUCTS

P74802M



Carter®
FUEL DELIVERY PRODUCTS

P74803M



Carter®
FUEL DELIVERY PRODUCTS

P74804S



Carter®
FUEL DELIVERY PRODUCTS

P74805S

FOTOGRAFÍAS



Carter®
FUEL DELIVERY PRODUCTS

P74811S



Carter®
FUEL DELIVERY PRODUCTS

P74814H



Carter®
FUEL DELIVERY PRODUCTS

P74816S



Carter®
FUEL DELIVERY PRODUCTS

P74819M



Carter®
FUEL DELIVERY PRODUCTS

P74823M



Carter®
FUEL DELIVERY PRODUCTS

P74824M

FOTOGRAFÍAS



P74826M



P74831M



P74832M



P74834M



P74835M



P74837M

FOTOGRAFÍAS



Carter
FUEL DELIVERY PRODUCTS

P74841M



Carter
FUEL DELIVERY PRODUCTS

P74849H



Carter
FUEL DELIVERY PRODUCTS

P74852S



Carter
FUEL DELIVERY PRODUCTS

P74853S



Carter
FUEL DELIVERY PRODUCTS

P74855S



Carter
FUEL DELIVERY PRODUCTS

P74857S

FOTOGRAFÍAS

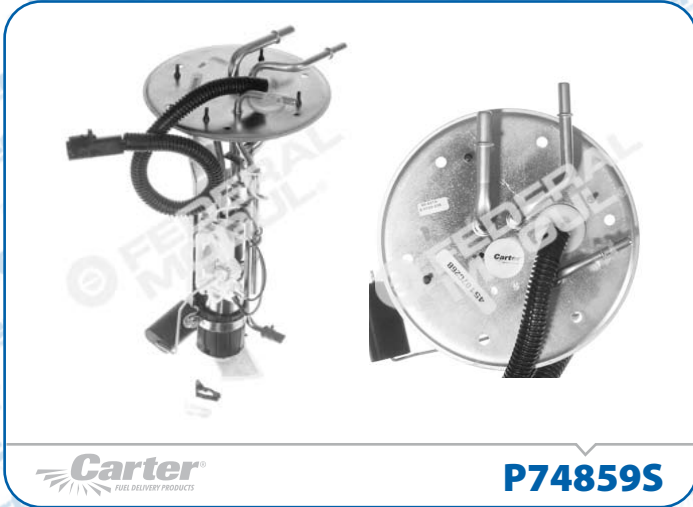

FOTOGRAFÍAS



Carter
FUEL DELIVERY PRODUCTS

P74879S



Carter
FUEL DELIVERY PRODUCTS

P74896S



Carter
FUEL DELIVERY PRODUCTS

P74900M



Carter
FUEL DELIVERY PRODUCTS

P74902M



Carter
FUEL DELIVERY PRODUCTS

P74912M



Carter
FUEL DELIVERY PRODUCTS

P74914M

FOTOGRAFÍAS

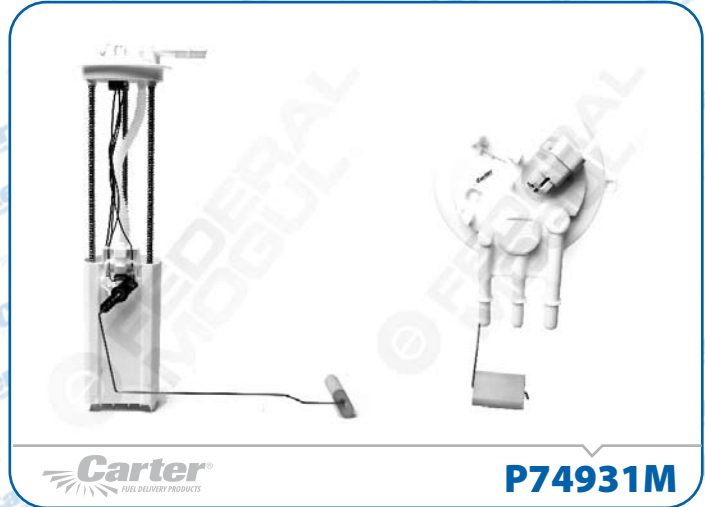

FOTOGRAFÍAS



Carter
FUEL DELIVERY PRODUCTS

P74952M



Carter
FUEL DELIVERY PRODUCTS

P74955M



Carter
FUEL DELIVERY PRODUCTS

P74960M



Carter
FUEL DELIVERY PRODUCTS

P74961M



Carter
FUEL DELIVERY PRODUCTS

P74963M



Carter
FUEL DELIVERY PRODUCTS

P74966M

FOTOGRAFÍAS



Carter®
FUEL DELIVERY PRODUCTS

P74978M

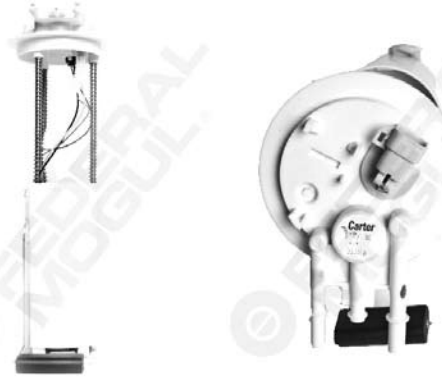

Carter®
FUEL DELIVERY PRODUCTS

P74979M



Carter®
FUEL DELIVERY PRODUCTS

P74987M



Carter®
FUEL DELIVERY PRODUCTS

P74988M



Carter®
FUEL DELIVERY PRODUCTS

P74989M



Carter®
FUEL DELIVERY PRODUCTS

P74990M

FOTOGRAFÍAS



Carter
FUEL DELIVERY PRODUCTS

P74997M



Carter
FUEL DELIVERY PRODUCTS

P74998M



Carter
FUEL DELIVERY PRODUCTS

P75006M



Carter
FUEL DELIVERY PRODUCTS

P75014M

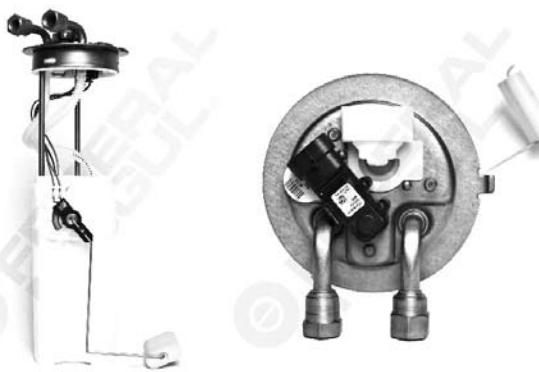

Carter
FUEL DELIVERY PRODUCTS

P75019M

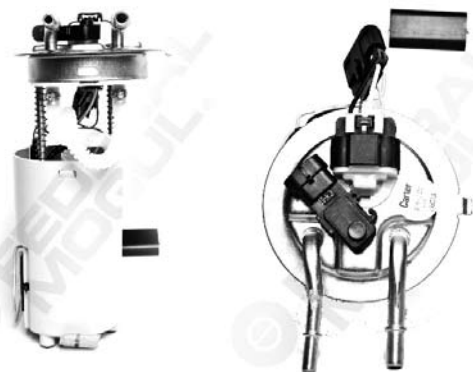

Carter
FUEL DELIVERY PRODUCTS

P75023M

FOTOGRAFÍAS

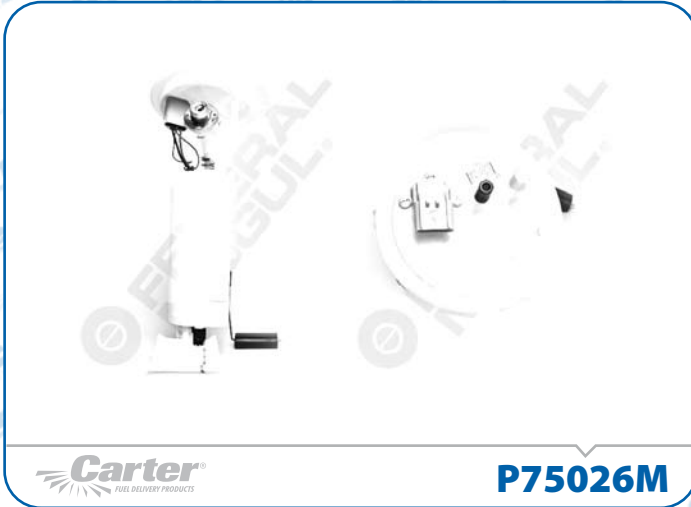

FOTOGRAFÍAS

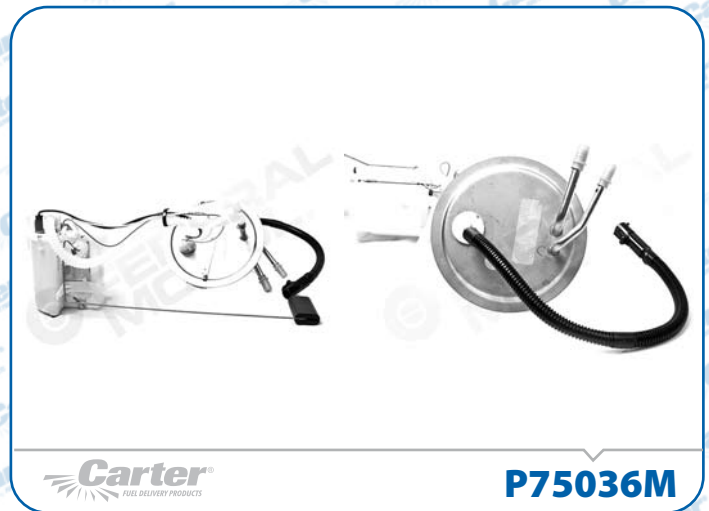
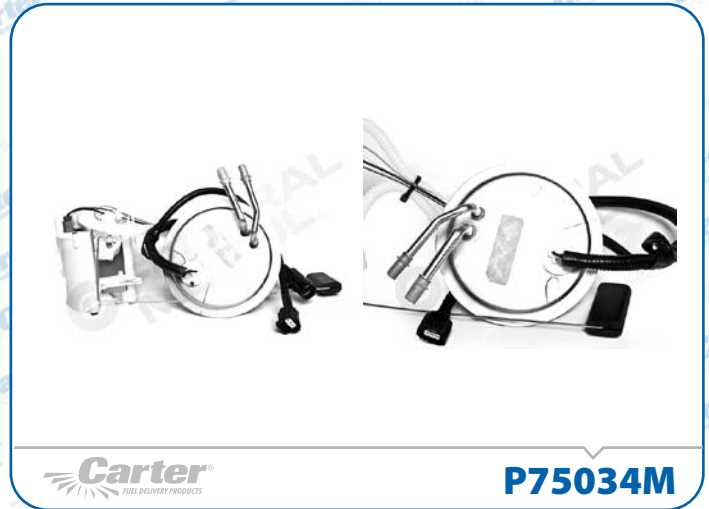

FOTOGRAFÍAS



Carter®
FUEL DELIVERY PRODUCTS

P75037M



Carter®
FUEL DELIVERY PRODUCTS

P75040M



Carter®
FUEL DELIVERY PRODUCTS

P75041M



Carter®
FUEL DELIVERY PRODUCTS

P75043M



Carter®
FUEL DELIVERY PRODUCTS

P75045M



Carter®
FUEL DELIVERY PRODUCTS

P75046M

FOTOGRAFÍAS



FOTOGRAFÍAS



P76014



P76015



P76016



P76017



P76018M



P76019

FOTOGRAFÍAS



Carter
FUEL DELIVERY PRODUCTS

P76020



Carter
FUEL DELIVERY PRODUCTS

P76022M



Carter
FUEL DELIVERY PRODUCTS

P76028

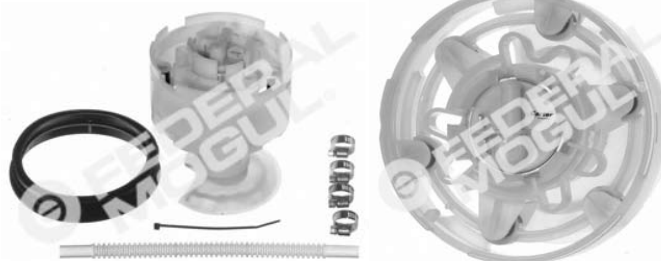

Carter
FUEL DELIVERY PRODUCTS

P76029M



Carter
FUEL DELIVERY PRODUCTS

P76032M



Carter
FUEL DELIVERY PRODUCTS

P76033M

FOTOGRAFÍAS



P76035



P76036



P76038



P76039



P76041M



P76061M

FOTOGRAFÍAS



Carter
FUEL DELIVERY PRODUCTS

P76065M



Carter
FUEL DELIVERY PRODUCTS

P76067M



Carter
FUEL DELIVERY PRODUCTS

P76084M



Carter
FUEL DELIVERY PRODUCTS

P76086M



Carter
FUEL DELIVERY PRODUCTS

P76096M



Carter
FUEL DELIVERY PRODUCTS

P76097M

FOTOGRAFÍAS



P76104



P76105



P76121M



P76122M



P76123M



P76128M

FOTOGRAFÍAS

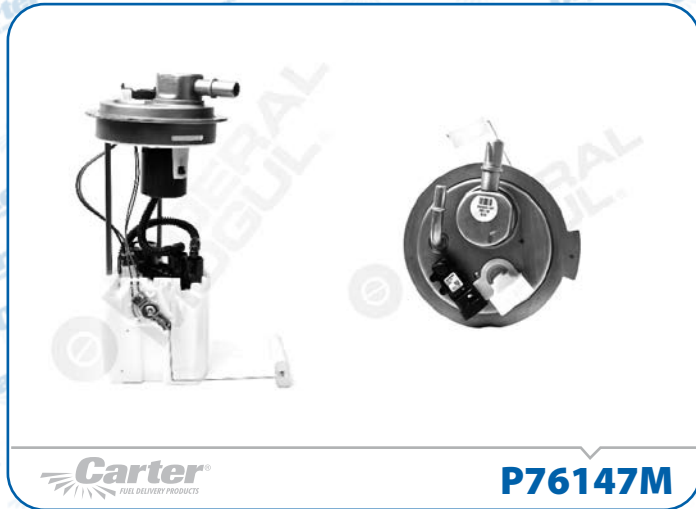
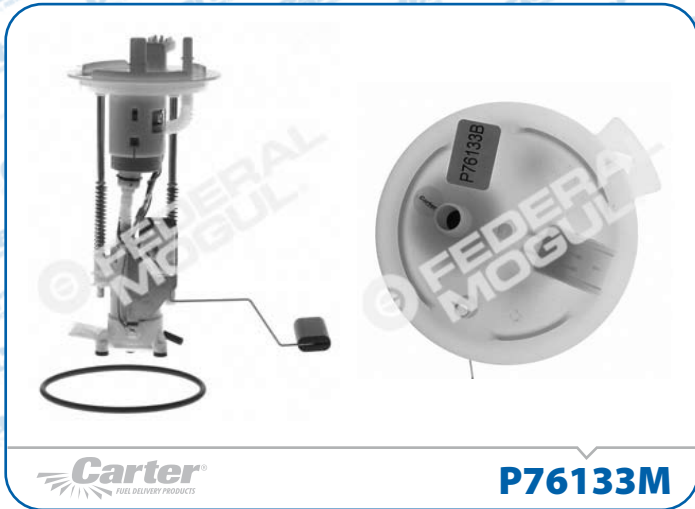
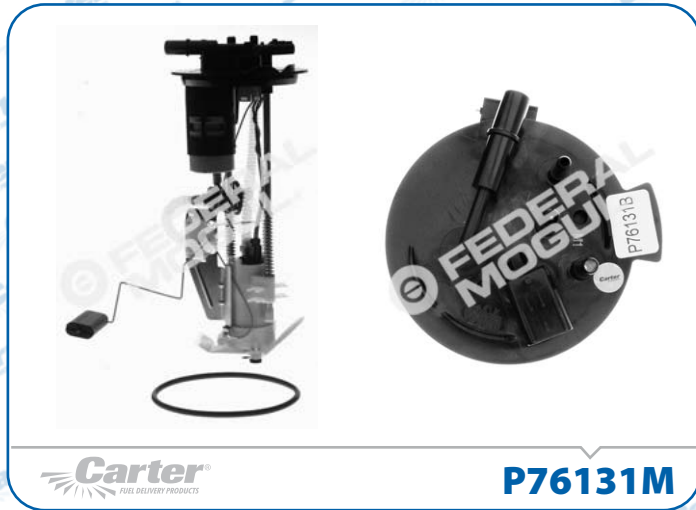

FOTOGRAFÍAS

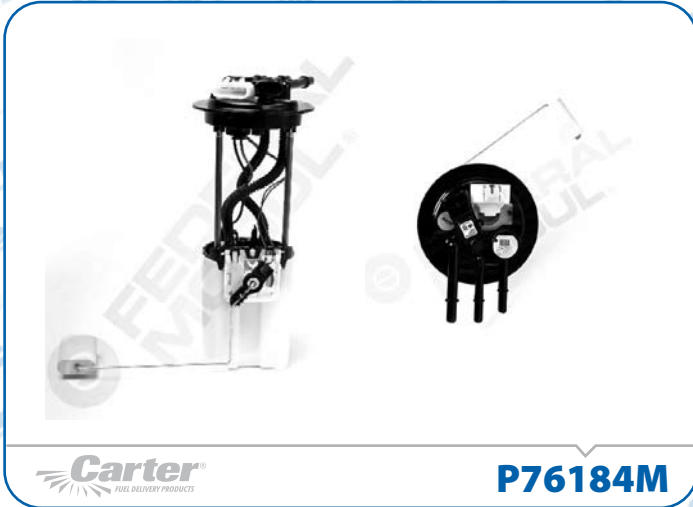

FOTOGRAFÍAS

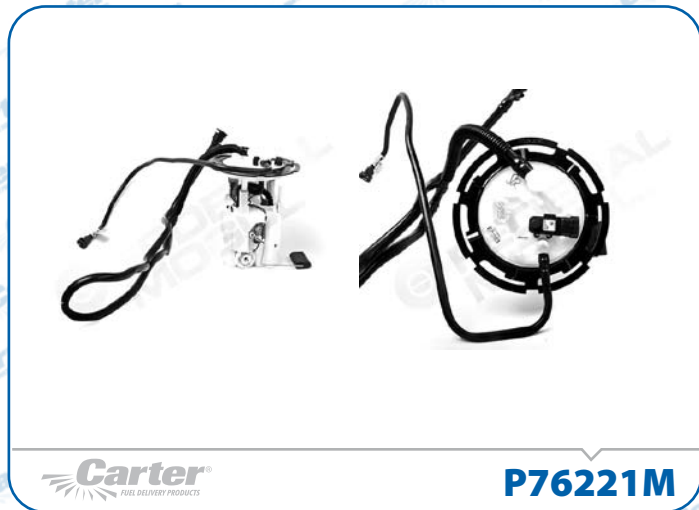

FOTOGRAFÍAS



Carter®
FUEL DELIVERY PRODUCTS

P76232M



Carter®
FUEL DELIVERY PRODUCTS

P76233M



Carter®
FUEL DELIVERY PRODUCTS

P76234M

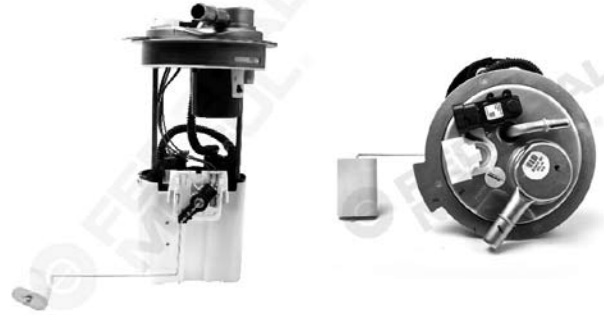

Carter®
FUEL DELIVERY PRODUCTS

P76237M



Carter®
FUEL DELIVERY PRODUCTS

P76242M



Carter®
FUEL DELIVERY PRODUCTS

P76243M

FOTOGRAFÍAS



Carter
FUEL DELIVERY PRODUCTS

P76245M



Carter
FUEL DELIVERY PRODUCTS

P76246M



Carter
FUEL DELIVERY PRODUCTS

P76254M



Carter
FUEL DELIVERY PRODUCTS

P76259M

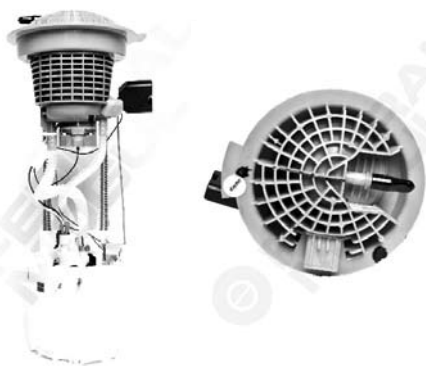

Carter
FUEL DELIVERY PRODUCTS

P76260M



Carter
FUEL DELIVERY PRODUCTS

P76306M

FOTOGRAFÍAS

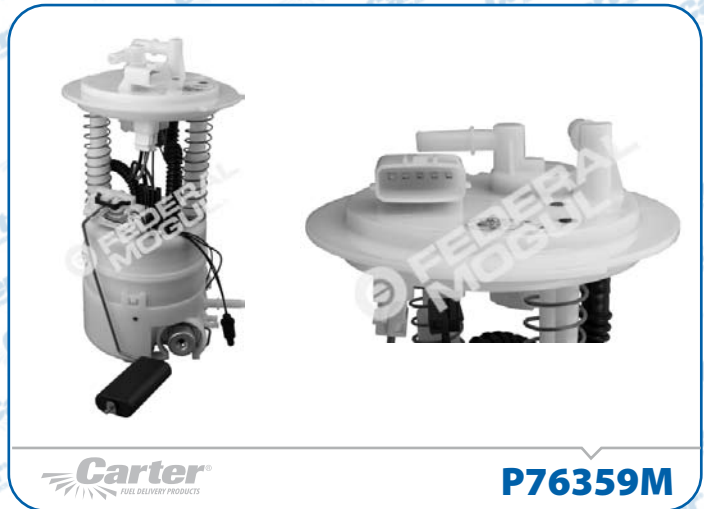
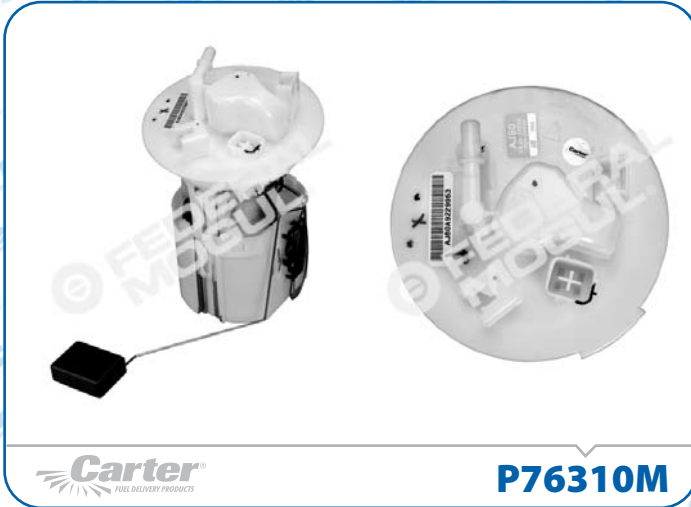

FOTOGRAFÍAS

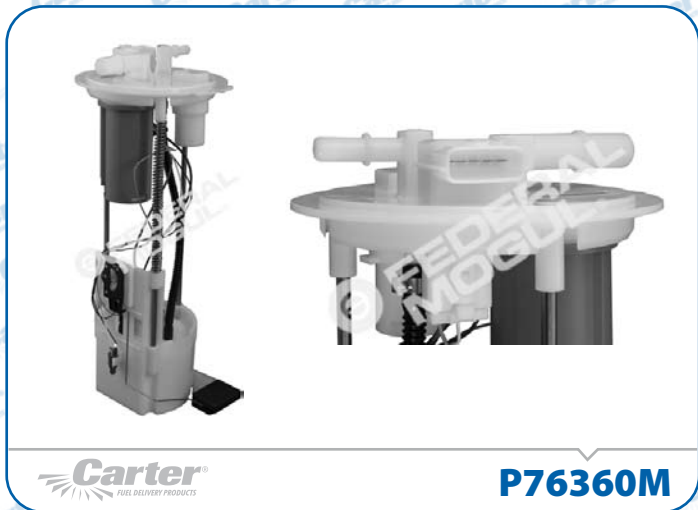

FOTOGRAFÍAS



FOTOGRAFÍAS



Carter®
FUEL DELIVERY PRODUCTS

P90050



Carter®
FUEL DELIVERY PRODUCTS

P90051



Carter®
FUEL DELIVERY PRODUCTS

P90070



Carter®
FUEL DELIVERY PRODUCTS

P90071



Carter®
FUEL DELIVERY PRODUCTS

P90090M



Carter®
FUEL DELIVERY PRODUCTS

P90107

FOTOGRAFÍAS



FOTOGRAFÍAS



P90212



P90220



P90221



P90240



P90241



P90420

FOTOGRAFÍAS



P90421



P90430



P90431



P90440



P90441



P90550

FOTOGRAFÍAS



Carter
FUEL DELIVERY PRODUCTS

P90551



Carter
FUEL DELIVERY PRODUCTS

P90600



Carter
FUEL DELIVERY PRODUCTS

P90601



Carter
FUEL DELIVERY PRODUCTS

P90606K



Carter
FUEL DELIVERY PRODUCTS

P90629



Carter
FUEL DELIVERY PRODUCTS

P90634

FOTOGRAFÍAS



P90676



P90677



P90693



P90771



P92024



P92068

FOTOGRAFÍAS



P92105



P95037



P96065



P96065



P96067

FOTOGRAFÍAS



M4503



M4530



M4641



M4642



M60003



M60036

FOTOGRAFÍAS



Carter
FUEL DELIVERY PRODUCTS

M60045



Carter
FUEL DELIVERY PRODUCTS

M60085



Carter
FUEL DELIVERY PRODUCTS

M60086



Carter
FUEL DELIVERY PRODUCTS

M60087



Carter
FUEL DELIVERY PRODUCTS

M60142



Carter
FUEL DELIVERY PRODUCTS

M60143

FOTOGRAFÍAS

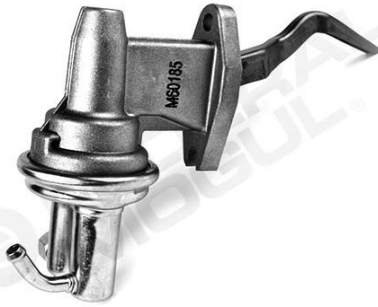

M60185



M60235



M60238



M60266



M60280



M60284

FOTOGRAFÍAS



Carter[®]
FUEL DELIVERY PRODUCTS

M60318



Carter[®]
FUEL DELIVERY PRODUCTS

M60321



Carter[®]
FUEL DELIVERY PRODUCTS

M60328



Carter[®]
FUEL DELIVERY PRODUCTS

M60330



Carter[®]
FUEL DELIVERY PRODUCTS

M60331



Carter[®]
FUEL DELIVERY PRODUCTS

M60335

FOTOGRAFÍAS



M60404



M60405



M60416



M60418



M60419



M60420

FOTOGRAFÍAS



Carter®
FUEL DELIVERY PRODUCTS

M60477



Carter®
FUEL DELIVERY PRODUCTS

M60509



Carter®
FUEL DELIVERY PRODUCTS

M60514



Carter®
FUEL DELIVERY PRODUCTS

M60519



Carter®
FUEL DELIVERY PRODUCTS

M60577



Carter®
FUEL DELIVERY PRODUCTS

M61067

FOTOGRAFÍAS



M6109



M6399



M6624



M6626



M6628



M6676

FOTOGRAFÍAS



Carter
FUEL DELIVERY PRODUCTS

M6736



Carter
FUEL DELIVERY PRODUCTS

M6737



Carter
FUEL DELIVERY PRODUCTS

M6738



Carter
FUEL DELIVERY PRODUCTS

M6750



Carter
FUEL DELIVERY PRODUCTS

M6807



Carter
FUEL DELIVERY PRODUCTS

M6882

FOTOGRAFÍAS



Carter®
FUEL DELIVERY PRODUCTS

M6935

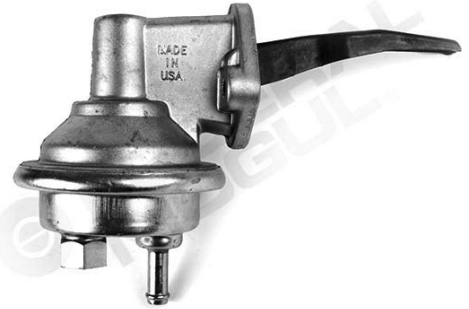

Carter®
FUEL DELIVERY PRODUCTS

M6951



Carter®
FUEL DELIVERY PRODUCTS

M6959



Carter®
FUEL DELIVERY PRODUCTS

M6962



Carter®
FUEL DELIVERY PRODUCTS

M6984



Carter®
FUEL DELIVERY PRODUCTS

M70041

FOTOGRAFÍAS



Carter
FUEL DELIVERY PRODUCTS

M70083



Carter
FUEL DELIVERY PRODUCTS

M70111



Carter
FUEL DELIVERY PRODUCTS

M70186



Carter
FUEL DELIVERY PRODUCTS

M70196



Carter
FUEL DELIVERY PRODUCTS

M70214



Carter
FUEL DELIVERY PRODUCTS

M70293

FOTOGRAFÍAS



M70307



M70308



M70319



M73031



M73060



M73098

FOTOGRAFÍAS

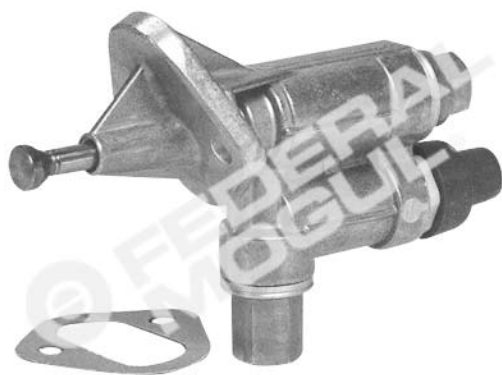

Carter
FUEL DELIVERY PRODUCTS

M73099



Carter
FUEL DELIVERY PRODUCTS

M73104



Diferencias entre Pines o Conectores



Carter muestra las razones por las que existen diferencias en la cantidad de Pines o conectores en la Bomba de Gasolina P-74634M.

Bombas de Gasolina Carter cuenta con la bomba P-74634M para:

MODELO	LITROS (PC)	VIN	LITROS (PC)	VIN	LITROS (PC)	VIN	LITROS (PC)	VIN	AÑOS	TRACCIÓN
Caravan	2,5 (153)	K	3.0 (181)	3	3.3 (201)	R			Entre	FWD
Grand Caravan			3.0 (181)	3	3.3 (201)	R			1991	FWD
Voyager			3.0 (181)	J	3.3 (201)	J,R			a	FWD
Grand Voyager			3.0 (181)	3	3.3 (201)	R	3.8 (230)	L	1995	FWD
Town & Country					3.3 (201)	R	3.8 (230)	L		FWD

Clientes nos hablan argumentando que a esta bomba le faltan "pines" o conectores, comentando que debe de llevar 5.

Para explicar esto, tengamos en cuenta lo siguiente:

Existen 3 diseños de bombas, en las que además de contar con diferencias en sus dimensiones, se cuenta con diferencias en las cantidades de pines, pudiendo haber de 3, 4 o 5 pines.

Este problema se origina debido el tipo de tracción de la unidad de "Tracción en las Ruedas Delanteras" se denomina FWD, y las unidades con "Tracción en las 4 ruedas" se denominan 4WD. Realmente la mayor cantidad de unidades que entraron al país via Frontera son de Tracción Delantera (FWD), para las cuales la bomba P-74634M utiliza 4 pines.

No. DE PARTE	TRACCIÓN	CANT. PINES
P-74634M	FWD	4 Pines
P-74656M	4WD	5 Pines
P-74674M	4WD	3 Pines



P-74656M y P-74674M Próximamente a la venta

Cada bomba que vende CARTER es previamente probado desde fábrica, obteniendo excelentes resultados, además recuerde que CARTER vende bombas con aplicación cerrada por lo que estos diseños de bombas de combustible NO SON INTERCAMBIABLES, ya que cada tipo de unidad utiliza una bomba diferente.



**Resolviendo Problemas,
la mejor opción para tu instalación.**





Disponible
EXCLUSIVAMENTE
en **CARTER**

Probador de circuitos eléctricos CV1000, para bomba de combustible

El probador de circuitos Carter® CV1000 ha sido diseñado para verificar las condiciones del circuito eléctrico de la bomba de combustible.

Éste determinará si el circuito eléctrico de la unidad esta funcionando inadecuadamente (y contribuyendo a una situación de falta de combustible) o un funcionamiento inadecuado de la misma bomba.

El probador Carter® CV1000 iluminará con un LED color rojo o verde, indicando los resultados de la condición de la prueba .



Rápida Conexión al arnés de los cables de la bomba de combustible del vehículo.



SOLUCIONES BOMBA DE COMBUSTIBLE



El probador Carter® CV1000 cuenta con :

- Cable de 4.30 mts
- Conectores para aplicaciones específicas



Si el circuito muestra que hay "FALLA", la causa de la falta de combustible probablemente no sea de la bomba y requiere una investigación adicional.



Si muestra "PASA", entonces el circuito está bien. La bomba ha fallado y necesita ser sustituida.

Productos que funcionan como el original. Innovaciones que impulsan desempeño. Consejos y soporte proporcionado por expertos. Con Soluciones **CARTER** para bombas de combustible, usted lo consigue todo.

Soluciones completas para el profesional del sistema de combustible

Bombas de Combustible CARTER con Nuevo Diseño P74006, P74074, P74037, P74167



PASO 1

Una vez retirado el ensamble, verifique la posición del cedazo tomando como referencia el tubo de salida del combustible, esto le servirá para colocar el nuevo cedazo en la misma dirección.



PASO 5

La nueva bomba a instalar puede ser más pequeña que la que esta retirando, por lo que tendrá que utilizar una manguera a la medida, esto no afectara en ningún aspecto al desempeño de la bomba.



PASO 2

Desconecte los cables que van conectados a la motobomba



PASO 6

Utilice una manguera a la medida, presente la bomba en la base considerando la altura del soporte, sobreponga la manguera a la altura que requiera en el tubo de salida y corte.



PASO 3

Retire el tacón de hule, quite la bomba evitando jalar o estirar demasiado la base del ensamble. Si el diseño de la bomba utiliza abrazaderas en la manguera, aflójelas antes de quitar la bomba.



PASO 7

Una de las fallas más comunes se debe al mal estado físico del cableado, CARTER incluye los cables para armar el arnés de acuerdo a las necesidades, así como otros componentes útiles para una correcta instalación.



PASO 4

La nueva bomba con el nuevo diseño CARTER ya no requiere el uso del damper o pulsador, por lo que este ya no deberá ser re-utilizado.



PASO 8

Coloque la cubierta aislante y el soporte en la bomba, a continuación instale la bomba colocando la manguera que se agregó a esta en el tubo de entrada del ensamble y apriete perfectamente las 2 abrazaderas.

Bombas de Combustible CARTER con Nuevo Diseño P74006, P74074, P74037, P74167



PASO 9

Conecte los cables del arnés, un extremo a la terminal positiva y otro a la negativa. Enseguida, sobre la referencia del Paso 1 coloque el cedazo hasta que este quede perfectamente fijo y alineado.

Nuevo Diseño



BENEFICIOS DEL NUEVO DISEÑO:

- Diseño actualizado y mejorado.
- Menos consumo de amperaje.
- Más silenciosa.
- Mayor capacidad de filtración.
- Mayor vida útil.
- Disminución de la pérdida de giro.
- Misma generación de presión (en el sistema).
- Arnés incluido en el kit.
- Cedazo mejorado, diseño exclusivo CleanScreen de CARTER.
- Disponibilidad de 5 cables, conectores para su instalación.
- Válvula de sobre presión (dispositivo de seguridad).



CleanScreen™

Tecnología CARTER

Los cedazos **CleanScreen™** de CARTER están diseñados para reducir drásticamente los problemas de suministro de combustible.

De esta manera los cedazos **CleanScreen™** te ofrecen el doble de capacidad de filtración en comparación con los cedazos convencionales de Equipo Original y mercado de repuesto.

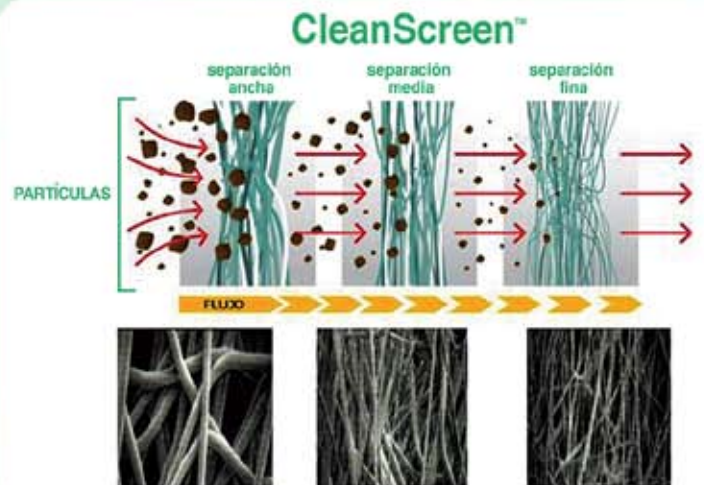

- ① Más capacidad de filtrado.
- ② Menos obstrucción.
- ③ Mayor durabilidad de la motobomba.



Carter®
FUEL DELIVERY PRODUCTS

Pregunta por los números de parte con Cedazos "CleanScreen"

El sistema de combustible incluye: la bomba en el tanque, regulador de presión en línea, filtro e inyectores, así como las líneas eléctricas que suministran el poder a la bomba. Antes de que se le dé un servicio a un vehículo, debes hacer una serie completa de pruebas y diagnósticos para saber si es necesario reemplazar un componente.

Estas pruebas incluyen:

- Prueba de presión de combustible.
- Prueba de flujo pleno.
- Prueba de caída de voltaje.

(Estas pruebas pueden indicar la necesidad de una simple reparación, que puede ayudar a ahorrar dinero evitando molestias, asegurando una libre instalación y rendimiento).

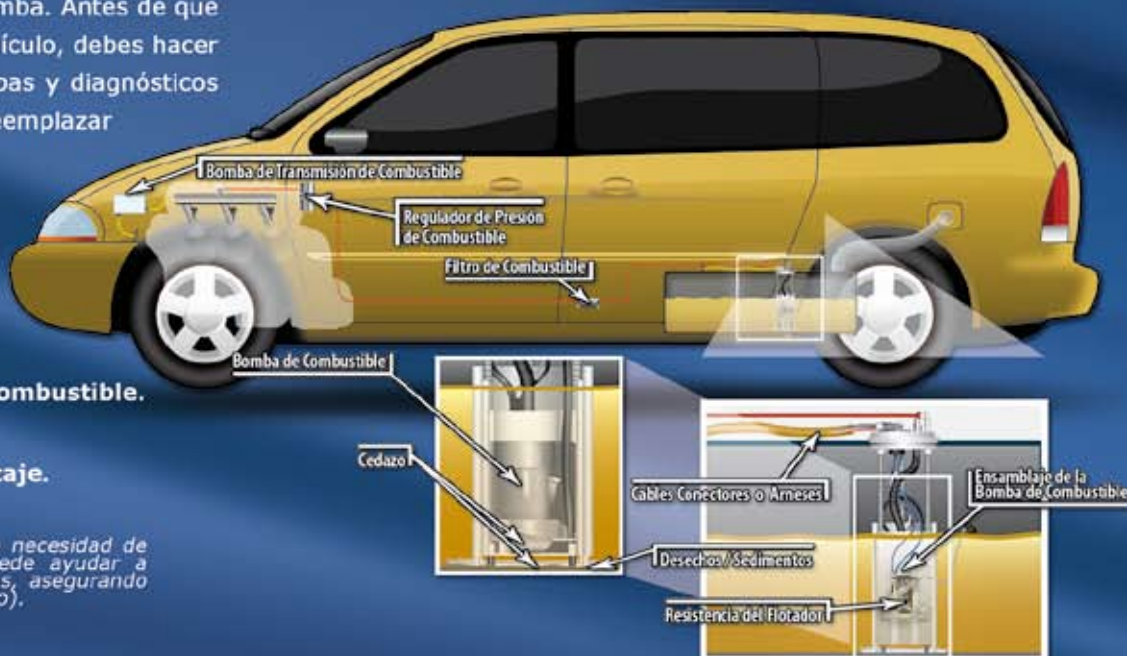

La mayoría de los vehículos modernos, utilizan una bomba de combustible eléctrica en el tanque, que puede incluir:

- **Cables conectores o arneses:**
Para conectar la bomba eléctrica con el sistema eléctrico.
- **Bomba:**
Empuja el combustible del tanque a los inyectores en el motor.
- **Cedazo:**
Filtra el combustible antes de que entre a la bomba.
- **Resistencia del flotador:**
Proporciona la señal del medidor indicando la cantidad de combustible en el tanque.
- **Regulador de presión:**
Controla las variaciones de presión de combustible en el sistema de alimentación.

Siga estos diez pasos, cuando sustituya su bomba de combustible:

1. Desconecte el cable negativo de la batería.
2. Libere la presión residual del riel de inyectores.
3. Vacíe el tanque, filtre y guarde el excedente de combustible.
4. Inspeccione las líneas de combustible y las conexiones eléctricas (cableado). (El arnés o conexión eléctrica, puede necesitar ser sustituida a un costo simbólico).
5. Soporte el tanque de combustible y afloje los tornillos de los tirantes del tanque.
6. Baje el tanque, prestando atención a la posición del reborde de la bomba.
7. Quite el arillo de cierre del ensamble de la bomba y limpie las partículas o suciedad de su alrededor.
8. Retire el módulo de la bomba de combustible (almacenando el resto del combustible).
9. Inspeccione el tanque y límpielo completamente, removiendo cualquier contaminante. (Es recomendable que el tanque sea limpiado en un taller especializado, el costo resultará insignificante y el beneficio será notable).
10. Instale el cedazo de la bomba y la bomba completa en el tanque; ensamble y pruebe

Bomba de Gasolina

Número Nuevo Multi-Funcional

P-54000

P-74006
P-74074
P-74037
P-74167

Nuestra principal prioridad siempre serán las necesidades de nuestros clientes, es por eso que CARTER lanzará al mercado la Nueva Bomba de aplicación Multi-Funcional P-54000, equivalente a las bombas P-74006, P-74037, P-74074 y P-74167.

Así es, con el fin de ofrecerte un mejor producto que cubra con todas tus necesidades, Carter ha creado Una única bomba con las especificaciones de esas Cuatro (1 bomba x 4)

Podrás seguir utilizando estas 4 bombas, solo que ahora también tendrás la posibilidad de utilizar la Bomba P-54000, con la ventaja de que es un único número de parte que te ofrece las características y valores de las cuatro bombas mencionadas.

» ¿Por qué hacer este cambio?

- Volver al diseño anterior
- Facilitar la disponibilidad, costo e inventarios
- Cuerpo más largo, igual al diseño acostumbrado
- Construcción interna mejorada, más resistente a los líquidos contaminantes
- Cambio en la construcción del impulsor (Antes-Aspas, Ahora-Turbina)
- Bomba **Tipo 4 Multifunción** (no es universal)
- Menor consumo de amperes
- **15 % más flujo**
- Calidad **CARTER** y respaldo **Federal-Mogul**
- Probadas al 100%, para un mejor desempeño
- Más silenciosa: tan solo 58 dbl
- Garantizada al 100%



» Kit completo que consta de:

- **1 Moto-bomba**
- **1 Cedazo CleanScreen**
- **2 Abrazaderas**
- **1 Tramo de manguera**
- **1 Conector**
- **1 Liga**
- **1 Base de instalación**



www.federalmogul.com

